



CONFIGURATION AND INSTALLATION MANUAL

**GENPLEX 3G, 10G & 12G REPEATER
REGEN REPEATER**

MultiDyne Product for Single and Double Fiber Solutions



MultiDyne
Harnessing The Power of Light

10 NEWTON PLACE
HAUPPAUGE, NY 11788 USA
(877) 685-8439 / (516) 671-7278 / FAX (516) 671-3362
sales@multidyne.com
www.multidyne.com

MULTIDYNE, the Multidyne logo,
are registered trademarks of MULTIDYNE Electronics, Inc.

Copyright 2019 MULTIDYNE Electronics, Inc., Hauppauge, New York.

Printed in the United States of America.







All Rights Reserved.

Contents of this publication may not be reproduced in any form without the written permission of
MULTIDYNE Electronics, Inc.

This product was designed and manufactured in the
UNITED STATES of AMERICA

Important Safety Information

- Do not use this apparatus near water.
- Clean only with lint free dry cloth.
- Do not block any ventilation openings.
- Do not install near any heat sources such as radiators, heat registers, stoves, or other apparatus (including amplifiers) that produce heat.
- Do not defeat the safety purposes of the grounding-type plug. A ground type plug has two blades and a third grounding prong. The third prong is provided for your safety. If the provided plug does not fit in to your outlet, consult an electrician for replacement of the obsolete outlet.
- Install in accordance with the MultiDyne® installation instructions.
- Install all peripheral equipment (cameras, routers, etc.) in accordance with the manufacturer’s instructions and safety requirements.
- Protect the power cord from being walked on or pinching particularly at plugs, convenience receptacles, and point where they exit from the apparatus.
- Only use attachments/accessories specified by MultiDyne®.
- Use only with the cart, rack, stand, tripod, bracket, or table specified by MultiDyne®, or sold with the apparatus. When a cart is used, use caution when moving the cart/apparatus combination to avoid injury from tip-over.
- Follow all local Electrical Codes for Grounding, Lightning Arrestment and Surge Protection. Unplug this apparatus during lightning storms or when unused for long periods of time.
- All Electrical Work to the facility must be performed by a qualified Licensed Electrician. All local Electrical Codes must be followed and, if necessary, must be inspected by a Local or State Inspector.
- All servicing of MultiDyne equipment must be performed at the factory by a MultiDyne trained service technician or engineer.
- Throughout this manual, a number of Warnings and Cautions and Notes may be presented to alert the user to important safety or operating information.
- Always adhere to local building, safety and fire prevention codes during the installation and operation of this product.
- Use only power cords that were shipped with specified for this product and certified for the country of use.
- Connect the unit only to a power source with the specified voltage rating.
- Unless otherwise stated in the Installation Instructions, and in adherence to local Electrical Codes MultiDyne® Equipment should only be plugged into a standard 15 amp dedicated circuit.

	Warning –indicate danger that requires proper procedures or practices to prevent injury or death to personnel.
	Cautions indicate proper procedures or practices to prevent damage to equipment or property.
	Warning –The safe operation of this product requires that a protective earth connection be provided. A grounding conductor in the equipment’s mains supply cord provides this protective earth. To reduce the risk of electrical shock to the operator and service personnel, this ground conductor must be connected to an earthed ground. The mains plug shall remain readily operable.
	Warning –The apparatus shall not be exposed to dripping or splashing and that no objects filled with liquids, such as vases, shall be placed on the apparatus.
	Warning - This symbol on the equipment indicates for use at altitudes not exceeding 2000 m.
	Warning - Contact your local authority for further details on the correct disposal of this waste, in accordance with your national legislation.

Laser Safety Information

This unit is classified as a **CLASS 1 LASER PRODUCT** according to EN60825-1 (EU) and FDA 21CFR 1040.10 (USA). Class 1 laser products are considered safe and do not result in biological hazard if used according to these instructions.







	Warning – Use of controls, adjustments or performance of procedures other than those specified herein may result in hazardous radiation exposure.
	Warning – Never look directly into the end of the optical fiber while either end of the system is operating.
	Warning – Never clean an optical fiber connector on equipment or cable that is carrying light.
	Warning – Always use dust caps on fiber optic connectors when cables are not connected. This will protect the connector from damage and accidental exposure of a human eye to an operating laser.

TABLE OF CONTENTS

INTRODUCTION	1
Overview	1
Repeater Models.....	1
Unpacking	1
FUNCTIONAL DESCRIPTION	2
GenPlex Repeater	2
Regen Repeater	2
INSTALLATION	3
Tools and Equipment Needed	3
Network Configuration	3
Mounting	4
Optical Budget.....	4
Connections.....	4
TECHNICAL SPECIFICATIONS	5
GenPlex Mechanical, Environmental.....	5

INTRODUCTION

Overview

The purpose of this manual is to provide configuration information and installation instructions for GenPlex and Regen Repeaters. The repeaters are sold in pairs with an A model connected to the Hybrid Universal Transceiver (HUT) on the Camera side and a B model connected to a HUT for the Camera Control Unit (CCU) side. The GenPlex are devices used with the HUT to increase the range of the fiber connection. The GenPlex models that can be ordered for 3G, 10G and 12G.

Repeater Models

Qty	Repeater	Model Number	Use in Network
1	GenPlex	GP-3G-20-ST3-A	Camera/HUT Side
1	GenPlex	GP-3G-20-ST3-B	CCU/HUT Side
1	GenPlex	GP-10G-40-ST3-A	Camera/HUT Side
1	GenPlex	GP-10G-40-ST3-B	CCU/HUT Side
1	GenPlex	GP-12G-10-ST3-A *	Camera/HUT Side
1	GenPlex	GP-12G-10-ST3-B *	CCU/HUT Side
1	Regen	RGX-10G-40-ST4-A	Camera/HUT Side
1	Regen	RGX-10G-40-ST4-B	CCU/HUT Side

**The 10G GenPlex can be special ordered for a distance of 80km with an optional Dispersion Compensation Module (DCM) unit.*

Unpacking

GenPlex and Regen Repeaters are shipped as a pair within a single container or part of a larger container when ordered as part of a network. The container will contain:

- Two or more GenPlex or Regen Repeater models.
 - Verify the Quantity of the order against the shipping manifest.
 - Verify the Model Numbers based on the order placed and the table below.
- Two or more AC/DC Power Cords and Power Supplies for the repeater devices.
- Rack Mount (Metalwork) for installing in a 1U Rack (if ordered).
- Mounting Cover Plates to dress off unused Mounting Locations
- Bag of connectors and connecting hardware needed to complete installation.

Carefully remove the repeaters from packaging and place onto stable flat surface. Packaging material should be recycled as appropriate to local area requirements.

FUNCTIONAL DESCRIPTION

GenPlex Repeater

GenPlex Repeater models available to enhance signal strength for distances up to 40km ± 2Km. These repeaters are designed for optimum performance in support of any network design and a multitude of camera models and manufacturers. Each GenPlex Repeater is configured internally with Small Factor Pluggable (SFP) module and Wavelength Division Multiplexing (WDM) devices of specific values to accommodate all single fiber and double fiber network solutions. A breakdown of the internal workings of the GenPlex repeater is shown in the table below.

Model Number	External Connections	Internal Configuration	Use
GP-10G-40-ST3-A	1 AMP OUT, 1 OPTICAL IN, 1 COMMON	1 1310 SFP 1 1550 SFP 1 WDM	Camera/HUT Side Double Fiber Solution
GP-10G-40-ST3-B	1 AMP OUT, 1 OPTICAL IN, 1 COMMON	2 1310 SFP 1 WDM	CCU/HUT Side Double Fiber Solution

Regen Repeater

There are four Regen Repeaters models available to enhance signal strength to 40km ± 2Km. These devices are designed for optimum performance in support of any network design and a multitude of camera models and manufacturers. Each Regen Repeater is configured with SFP modules of specific values to accommodate all single fiber and double fiber network solutions. A breakdown of the internal workings of each Regen repeater is shown in the table below.

Model Number	External Connections	Internal Configuration	Use
RGX-10G-40-ST4-A	2 A 2 B	2 1310 SFP 1 WDM	Camera/HUT Side 35km Distance
RGX-10G-40-ST4-B	2 A 2 B	2 1310 SFP 1 WDM	CCU/HUT Side 15km Distance

INSTALLATION

Tools and Equipment Needed

The GenPlex and Regen Repeaters require standard hand tools to complete the installation. There is NO special equipment needed.

Network Configuration

The diagram below shows the basic GenPlex and Regen network configurations commonly used for this product. This generic diagram illustrates a 40km ± 2Km network where the GenPlex and Regen repeaters are installed.

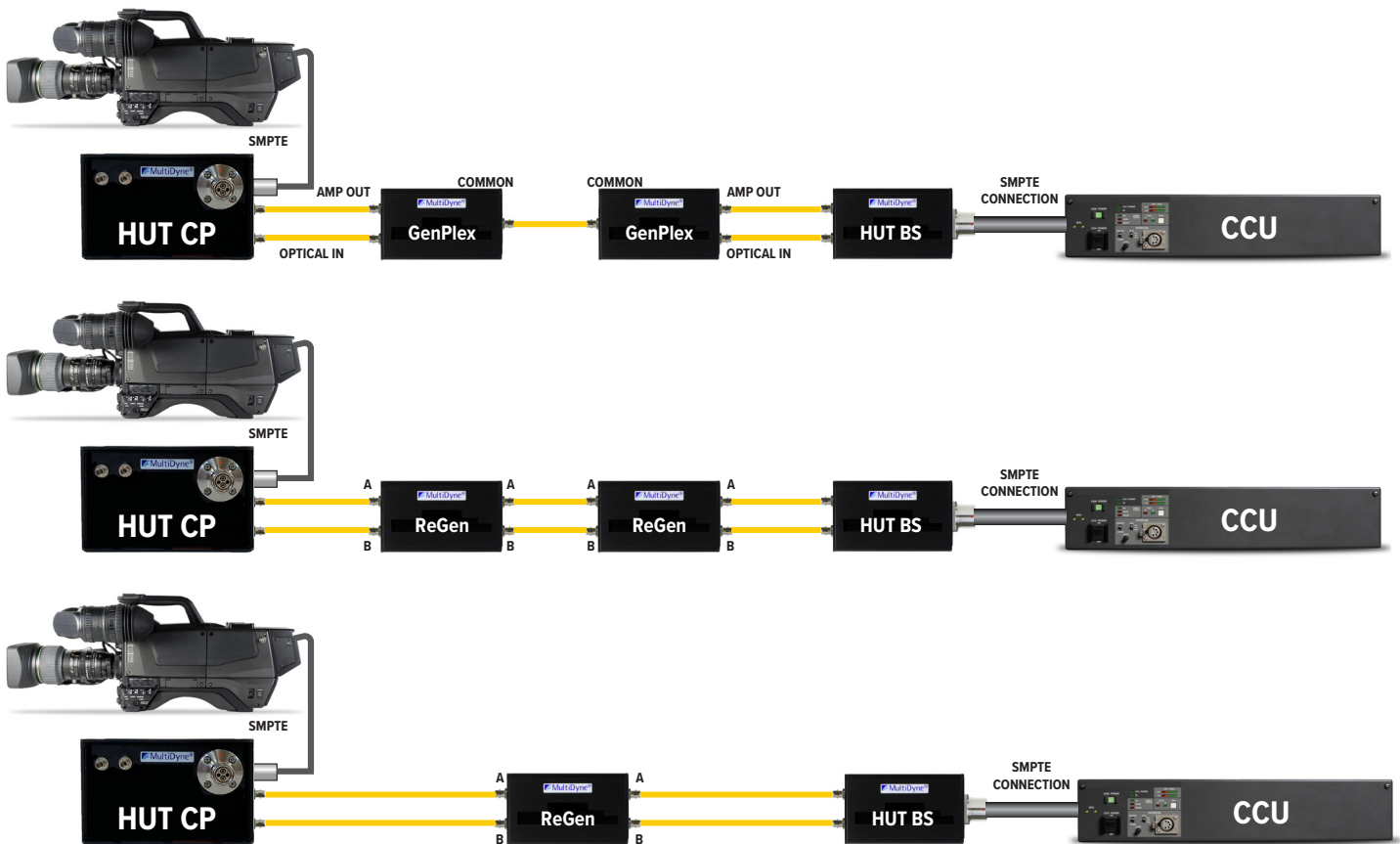

Mounting

The repeaters are strategically placed in the middle of long distance runs to regenerate signal strength. The GenPlex or Regen boxes can be located within an existing equipment rack or any hard flat surface where the fiber cable is being routed. The device requires no additional grounding or start up procedures.

Existing Equipment Rack Mounting:

NOTE

The Rack Mount aluminum metalwork plate can be used for installing the Repeater(s) in a 1U Rack. The plate can accommodate six Repeater installations. For installations that do not use six Repeaters, a blank dress plate is provided to cover the unused openings.

- Remove the four plate mounting screws and position the Repeater to the desired Rack Mount plate location. Install the four screws that secure the Repeater to the plate.
- At the rack where the Repeater(s) is to be located make sure all wiring and loose equipment has been cleared away to avoid any obstructions. Make sure the front and rear portions of the rack are clear so that the wiring can be routed to the Repeater(s).
- Slide the Rack Mount plate with Repeater(s) installed into the rack and secure with attaching hardware.
- Using the Connections as a guide install the cables to the Repeater(s).
- Position the dress cover plates over the unused openings and secure with attaching hardware.

Optical Budget

The optical power budget is the minimum amount of power needed to be applied to the GenPlex or Regen Repeaters from the fiber communications link. Optical power loss can be caused by various means including splices, coupling loss, connector loss and attenuation. It is important to the operational integrity of the GenPlex and Regen Repeaters that adequate optical power signal strength be available. The optical power budget is specified in decibel (dB) and optical power budget for the GenPlex is 16dBm + 2dBm.

Connections

Connections for the GenPlex Repeaters are simple and provided in the table below.

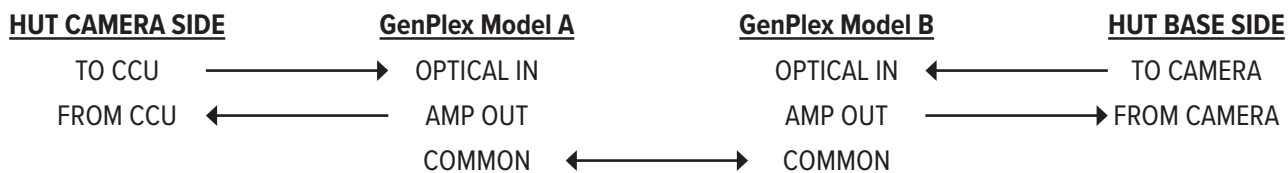

Connections for the Regen Repeaters are simple and provided in the table below.

Plug the AC/DC Power Cord Converter connector into the GenPlex unit at POWER 9-24VDC and secure. Plug the other end of the converter cord into wall or suitable Power Strip/Surge Suppressor.

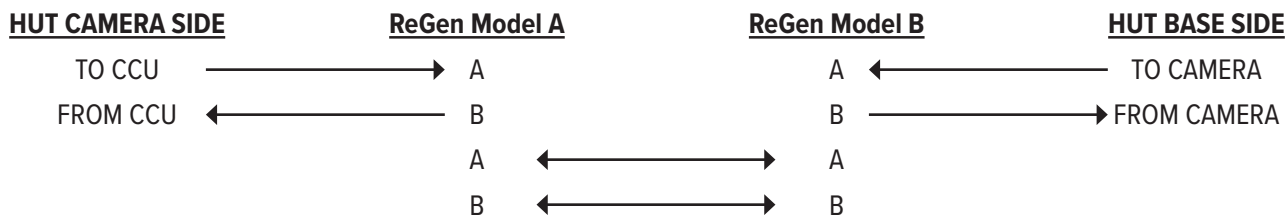

TECHNICAL SPECIFICATIONS

Mechanical, Environmental

Dimensions	L 5.625 x W 2.625 x H 1.625 inches
Operating Temperature	0 to 50 deg C
Power Requirement	9 – 18 VDC
Optical Connectors	3 ST