

FEATURES

- ▷ Full support of 3G/HD/SD-SDI and ASI/DVB
- ▷ Reclocking can be enabled or disabled for each input channel
- ▷ One-card solution for distribution of 4K quadrant-division content over 3G/HD/SD-SDI interfaces
- ▷ Excellent receive performance – EQ allows 1694A cable lengths up to 120m (3G) / 160m (HD) / 400m (SD)
- ▷ Flexible output crosspoint allows card to function as quad-channel 1x4, dual-channel 1x8, or single-channel 1x16 reclocking DA
- ▷ Failsafe mode automatically switches to selected secondary input on loss of primary input
- ▷ Input data rate auto-detection for all industry-standard data rates
- ▷ All outputs are non-inverting – ASI can be outputted on any output
- ▷ Card edge and DashBoard™ status and individual input lock indicators

APPLICATIONS

- ▷ Critical Transmission Path Protection
- ▷ Quad-Link 4K Distribution
- ▷ Utility Router
- ▷ Bulk ASI Distribution

Supports four input channels which can be crosspoint-routed to any of 16DA outputs

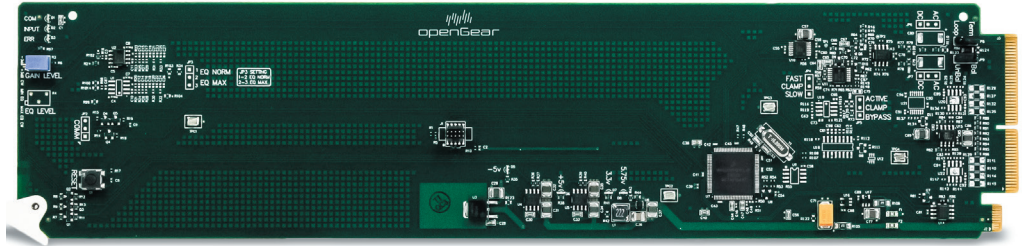

The OG-5330-DDA-Quad 3G 3G/HD/SD Quad-Channel Multi-Rate DA with x4 Output Crosspoint (Non-Reclocking) supports four input channels which can be crosspoint-routed to any of 16 DA outputs. OG-5330-DDA-Quad 3G is multi-rate, and supports SDI and ASI/DVB on all inputs and outputs with non-inverting outputs. The quad-input capacity provides a one-card solution for distribution of 4K quadrant-division content over 3G/HD/SD-SDI interfaces.

The extremely flexible crosspoint (which is user-configurable via DashBoard™ GUI remote control) allows quad 1x4, dual 1x8, single 1x16 and other routing possibilities (such as dual 1x4 plus a single 1x8). Any of the four input channels can be distributed or duplicated across four groups of 1x4 DAs, and any of the four inputs can be set to use an alternate failover input upon loss of signal.



Excellent receive performance allows receive EQ for up to 120m 3G and 160m HD cable length (1694A). Card edge and DashBoard™ remote status monitoring indicates input lock for each input channel. Up to 10 of the OG-5330-DDA-Quad 3G cards can be installed in a frame to provide 40 channels of input, with distribution to up to 160 outputs.

Full user DashBoard™ or Remote Control Panel remote control allows full status and control access locally or across a standard Ethernet network.

BLOCK DIAGRAM

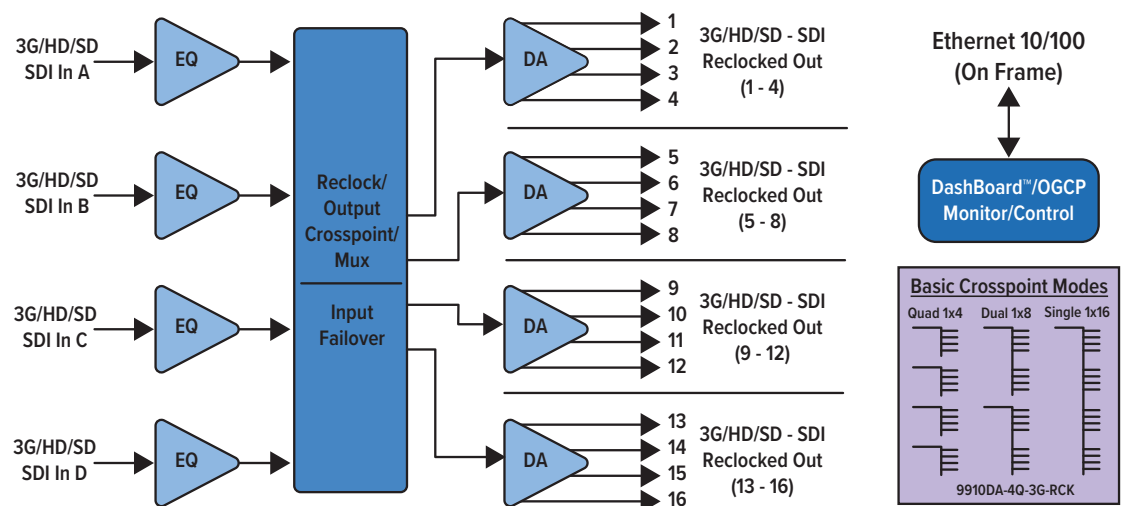

REAR MODULE MODELS

Rear I/O Module output designations here correlate to output numbers for four DA quadrants as shown in the card block diagram (for example, SDI OUT 3 in diagrams below is tied to (driven from) DA quadrant “SDI Out (1-4)” in the block diagram; SDI OUT 5 in diagrams below is tied to (driven from) DA quadrant “SDI Out (5-8)” in the block diagram). As such, SDI outputs within a

quadrant group can only be sourced from a particular input at one time (for example, if the card is set to feed SDI IN A to quadrant SDI Out (1-4), the rear module outputs 1 thru 4 will all output SDI IN A). Dissimilar inputs cannot be routed within a quadrant group (for example, SDI OUT 1 sourced from SDI IN A and SDI OUT 2 sourced from SDI IN B)

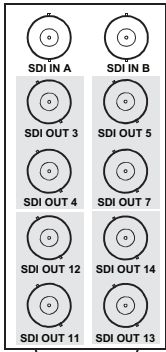

R4-5330-A

Note: When this rear module is used DashBoard or local control should only be set to use SDI IN A and/or SDI IN B. Either of these inputs can be routed to any of the output quadrant groupings shown (grouping shown in shaded areas).

When local control instead of DashBoard is used, input routing to output groups on this rear module is fixed.

The outputs shown here are all that is available using this rear module, with these outputs being a reduced subset of the maximum 16 available outputs. (For example, this rear module offers a reduced subset of DA quadrant SDI Out (1-4) (shown in the block diagram) consisting of SDI OUT 3 and SDI OUT 4 only.)

See Product Manual for more information.

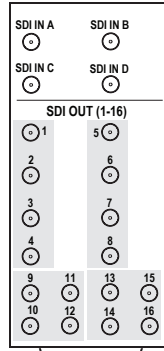

R4-5330-B
R4-5330-C

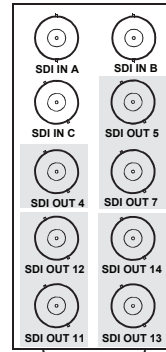

R4-5330-D

Note: When this rear module is used DashBoard or local control should only be set to use SDI IN A, SDI IN B and/or SDI IN C. Any of these inputs can be routed to any of the output quadrant groupings shown (groupings shown in shaded areas).

When local control instead of DashBoard is used, input routing to output groups on this rear module is fixed.

The outputs shown here are all that is available using this rear module, with these outputs being a reduced subset of the maximum 16 available outputs. (For example, this rear module offers a reduced subset of DA quadrant SDI Out (5-8) (shown in the block diagram) consisting of SDI OUT 5 and SDI OUT 7 only.)

See Product Manual for more information.

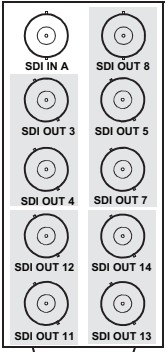

R4-5330-E

Note: When this rear module is used DashBoard or local control should only be set to use SDI IN A. This input can be routed to any of the output quadrant groupings shown (grouping shown in shaded areas).

When local control instead of DashBoard is used, input routing to output groups on this rear module is fixed.

The outputs shown here are all that is available using this rear module, with the outputs being a reduced subset of the maximum available 16 outputs. (For example, this rear module offers a reduced subset of DA quadrant SDI Out (1-4) (shown in the block diagram) consisting of SDI OUT 3 and SDI OUT 4 only.)

See Product Manual for more information.

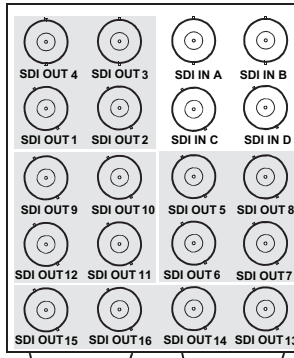

R4-5330-F



openGear

ORDERING INFORMATION

Part #	Description
OG-5330-DDA-Quad	3G/HD/SD Quad-Channel Multi-Rate DA with x4 Output Crosspoint (Non-Reclocking)
R4-5330-A	20-Slot Frame Rear I/O Module (Standard Width) (2) 3G/HD/SD-SDI Input BNC, (8) 3G/HD/SD-SDI Output BNCs
R4-5330-B	20-Slot Frame Rear I/O Module (Standard Width) (4) 3G/HD/SD-SDI Inputs, (16) 3G/HD/SD-SDI Outputs (DIN 1.0/2.3) (High Density)
R4-5330-C	20-Slot Frame Rear I/O Module (Standard Width) (4) 3G/HD/SD-SDI Inputs, (16) 3G/HD/SD-SDI Outputs (HDBNC) (High Density)
R4-5330-D	20-Slot Frame Rear I/O Module (Standard Width) (3) 3G/HD/SD-SDI Input BNC, (7) 3G/HD/SD-SDI Output BNCs
R4-5330-E	20-Slot Frame Rear I/O Module (Standard Width) (1) 3G/HD/SD-SDI Input BNC, (9) 3G/HD/SD-SDI Output BNCs
R4-5330-F	20-Slot Frame Rear I/O Module (Double Width) (4) 3G/HD/SD-SDI Input BNC, (16) 3G/HD/SD-SDI Output BNCs

TECHNICAL SPECIFICATIONS

Electrical

Power	3 Watts
-------	---------

3G/HD/SD-SDI / ASI Inputs

(4) 75Ω BNC inputs (A thru D)	(4) 75Ω BNC inputs (A thru D)
SDI Formats Supported	SMPTE 259M, SMPTE 292M, SMPTE 424M
SDI Return Loss	>15 dB up to 1.485 GHz; >10 dB up to 2.970 GHz

Receive Performance (Cable Length; Belden 1694A)

3 Gbps: 120m
1.485 Gbps: 160m
143-360 Mbps: 400m

3G/HD/SD-SDI / ASI Outputs

BNC outputs	(4x4) 75Ω BNCs (16 total). Each group of 4 outputs can be crosspoint connected to inputs A thru D.
Signal Level	800 mV nominal
Return Loss	>15 dB at 5 MHz - 1.485 GHz
Jitter (wideband)	HD < 0.2 UI
	>10 dB at 1.5 GHz to 3 GHz
Jitter (wideband)	HD: < 0.2 UI