



INSTRUCTION MANUAL

HD-3500 Series

**SERIAL DIGITAL VIDEO, DATA, AND AUDIO,
FIBER OPTIC TRANSPORT & DISTRIBUTION
SYSTEM FOR HDTV & SDTV**

MultiDyne
Video at Light Speed

10 Newton Place
Hauppauge, NY 11877 USA
1-877-685-8439 • 1-516-671-7278 • FAX (516)-671-3362
sales@multidyne.com
www.multidyne.com

MULTIDYNE and HD-3500 are registered trademarks of MULTIDYNE Electronics, Inc.

Copyright 2009 MULTIDYNE Electronics, Inc., Hauppauge, New York.
Printed in the United States of America. All Rights Reserved.
Contents of this publication may not be reproduced in any form without the
written permission of MULTIDYNE Electronics, Inc.

This product was designed and manufactured in the
UNITED STATES of AMERICA

TABLE OF CONTENTS

INTRODUCTION 1

FEATURES AND OPERATION 1

TRANSMITTER, HD-3500-FTX 2

RECEIVER, HD-3500-FRX 6

POWER REQUIREMENTS 10

INSTALLATION 10

APPENDIX A. PIN-OUT SPECIFICATION 11

APPENDIX B. BLOCK DIAGRAMS 12

APPENDIX C. TECHNICAL SPECIFICATIONS 14

APPENDIX D. OPTIONAL DIVING BOARD 16

INTRODUCTION

The [HD3500 Series](#) of stand-alone SMPTE 3G video High Definition Serial Digital Interface (HD-SDI) with audio and data transport systems extends the range limits of electrical interfaces, and combines audio and data along with the HD-SDI signal in a single optical fiber link. The system will transport digital signals from 5 Mbps up to 2.970 Gbps, analog audio, AES digital audio, serial data, intercom, tally, and General Purpose I/O (GPIO) signals.

Applications include transmission links for high definition or digital television, studio to transmitter; studio-to-studio, robotic studio cameras, studio to CATV head-end and backhaul feeds from special events. The transmitter and receiver units are available in portable or stand-alone and modular configurations ideal for both field and studio applications.

FEATURES and OPERATION

The HD3500 supports all popular standards for digital video transport such as SMPTE 259M-C, SMPTE 292M, and SMPTE 424, working at 270 Mbps, 1.495 Gbps, and 2.970 Gbps respectively. In addition, the HD-SDI interface also will transport signals compatible with DVB/ASI, and SMPTE 297M interfaces at the defined rates. The units include a digital reclocked DA and repeater for the SMPTE SDI standards mentioned above. For other standards and rates, the signal is automatically or manually passed thru without reclocking. For the SDI/HD-SDI input, the units include automatic cable equalization based on the data rate detected.

Separate from the SMPTE video transport, the HD-3500 also transports 4 analog audio channels with maximum configurable levels of 4dBu, 10dBu, 16dBu, or 28 dBu; 2 digital AES pairs up to 96Khz that cross convert with the 4 analog channels; and a bidirectional stereo channel for intercom applications with maximum level of 4dBu. The system also supports 4 GPIO bidirectional channels with open collector inputs capability and relay contact for the outputs; 1 bidirectional tally IO with open collector input and contact relay output; and 3 bidirectional serial data channels compatible with RS232 or RS422 transport up to 3Mbps.

To accomplish SMPTE video with bidirectional audio and data transport, 3 wavelengths are multiplexed over a single fiber using a CWDM module, a 1310nm optic used for SMPTE video, and 1490nm and 1550nm optics are used for the bidirectional audio and data transport. The SMPTE video input and output use standard BNC connectors while the audio and data use a DB44 connector with either a special breakout cable assembly or a diving board. See appendix A for pin-out information.

A Gigabit Ethernet and Sync Transport option is available, HD-3500-GE-TX and HD-3500-GE-RX, which adds a copper to fiber Ethernet media converter to each unit and a reference sync transport from the Rx unit to the Tx unit. Rates of 10/100/1000 Mbps are supported for Ethernet and supported sync formats are NTSC, PAL, and HD Tri-Level.

TRANSMITTER, HD-3500-FTX

The transmitter module front and back is shown in figure 1. In the back and from left to right it includes a DB44 connector for all audio and data IO; two serial digital video SMPTE 75 Ohm input BNC connectors, one for input and one for reclocked SDI / HD-SDI output loop; a single fiber output ST or SC connector; and a DC Jack power connector. In the front of the module we see 3 SMPTE SDI lock LEDs for 270 Mbps, 1.485 Gbps and 2.970 Gbps rates; SMPTE SDI CD (Carrier Detect) LED; 2 audio status LED that indicate channel 1 and 2 level, peak, or AES presence; 6 data activity LEDs to indicate TX and RX activity in the 3 data channels; a tally on indicator LED; a link status LED; and a power LED.

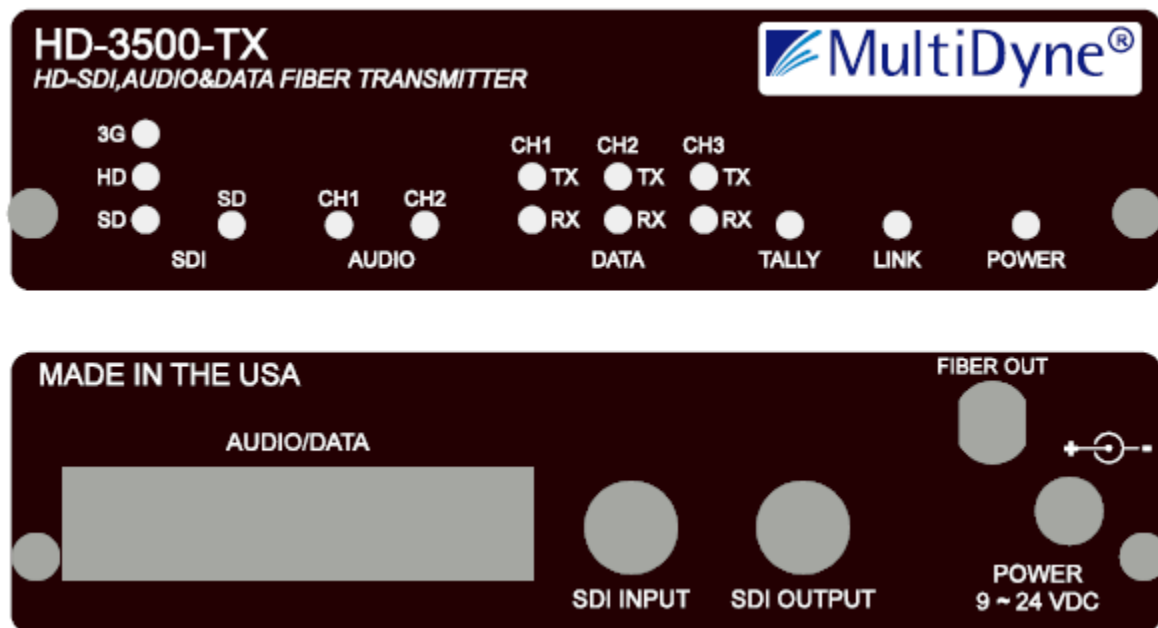

Figure 1. Front and Back of HD-3500-FTX

SMPTE video transport

The HD-3500-TX receives SMPTE video or other properly encoded data signals from 5Mbps to 3Gbps. The SMPTE video signal is connected to the 75 ohms BNC input connector in the back. Signals with rates from 19 Mbps to 3Gbps are then equalized. Equalization is used to help open the digital video eye pattern that may have been closed or deteriorated due to long coaxial cable runs. After equalization, the signal is reclocked and sent to the fiber transport and to a 75-ohm loop output, which is the second BNC connector in the back. The front rate LEDs indicate that a valid SMPTE rate is locked by the re-clocker PLL. The Carrier Detect (CD) LED indicates that a signal has been applied to the input. Carrier Detect is sensitive to digital carriers from 19Mbps to 3Gbps.

Non-SMPTE transport via the SMPTE interface

The HD3500 will operate normally by default with SMPTE video signals at the rates indicated earlier; however, other signals may need special settings. The SMPTE video input has a feature that automatically mutes signals as noise or other signals under 19Mbps. If you

need to transport these signals, the auto mute feature can be disabled changing the jumper J10 from the 1-2 to the 2-3 position, see figure 2 with default setting. Non-SMPTE standard signals should automatically put the reclocker into bypass mode; however, in some instances, if the signal has components close to the SMPTE frequencies, there may be glitches on the operation. To void this, there is another jumper, J5 that when inserted will force the reclocker into bypass mode. The default setting for J5 is open as shown below.

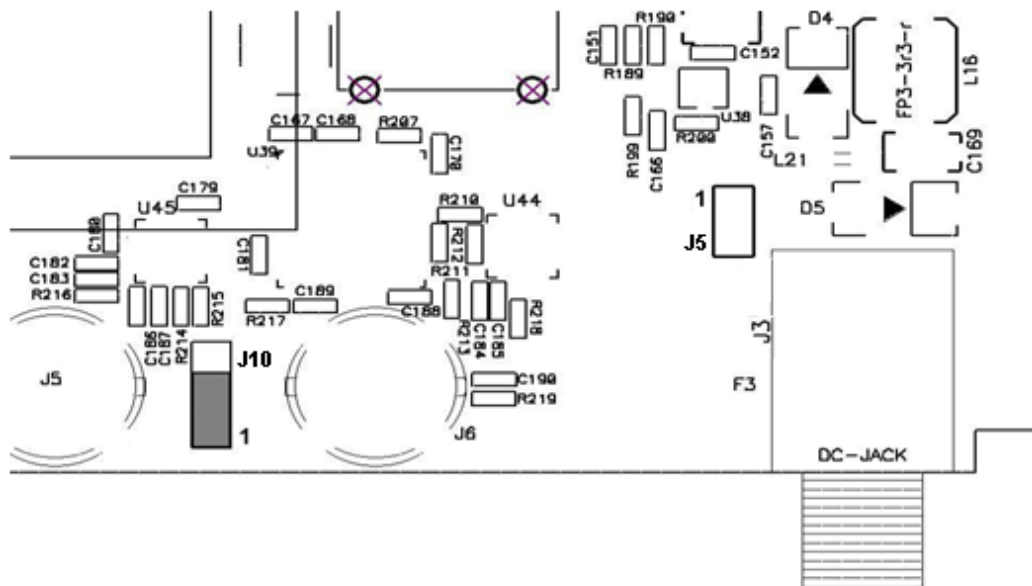

Figure 2. Default settings and placement for J10 and J5

Audio Transport

This unit can transport two balanced stereo pairs (4 monos), or two AES channels of high quality audio. The unit automatically detects if AES audio is present in each channel to be selected, otherwise the corresponding analog stereo pair is selected. The AES channels can be set for 110 ohms balanced input mode or 75 Ohms singled ended input (see table 1). The analog stereo pairs can be set for different full scale (FS) levels using a dip switch, 600 ohms input mode, or +6dB compensation (see tables 2 and 3). The audio LEDs indicate three possible statuses: constant blinking green indicates AES signal is present, green indicates analog level is present with a level from -8dBFS to -1dBFS, and red indicates clipping. Even if a tiny clip is detected, the red LED is held for a fraction of a second. In addition to these main audio channels, there is a bidirectional stereo channel for intercom applications. This channel has unbalanced inputs, and a maximum audio range of +4dBuFS

Sw 1 Position	Function	Setting (Default values in Bold)	
1	Data 1 Type	on=RS232	off=RS422
2	Data 2 Type	on=RS232	off=RS422
3	Data 3 Type	on=RS232	off=RS422
4	Analog Sampling	on=48KHz	off=96KHz
5	AES 1 Input	on = 75 Ohms AES3id Single Input	off = 110 Ohms AES3 Bal. Input
6	AES 2 Input	on = 75 Ohms AES3id Single Input	off = 110 Ohms AES3 Bal. Input

Table 1. Settings for AES Audio and Data Types

Sw 2 Position	Function	Setting (Default values in Bold)			
1-2	An. Audio 1 FS	on-on= 28dBu FS	on-off = 16dBu FS	off-on = 10dBu FS	off-off = 4dBu FS
3	Ch1 Left +6dB	on = 0dB (Hi Z)		off = +6dB (600 Ohm)	
4	Ch1 Left 600 Ohms	on = 600 Ohms		off = Hi Z	
5	Ch1 Right +6dB	on = 0dB (Hi Z)		off = +6dB (600 Ohm)	
6	Ch1 Right 600 Ohms	on = 600 Ohms		off = Hi-Z	

Table 2. Settings for Analog Audio Channel 1

Sw 3 Position	Function	Setting (Default values in Bold)			
1-2	An. Audio 2 FS	on-on= 28dBu FS	on-off = 16dBu FS	off-on = 10dBu FS	off-off = 4dBu FS
3	Ch2 Left +6dB	on = 0dB (Hi Z)		off = +6dB (600 Ohm)	
4	Ch2 Left 600 Ohms	on = 600 Ohms		off = Hi Z	
5	Ch2 Right +6dB	on = 0dB (Hi Z)		off = +6dB (600 Ohm)	
6	Ch2 Right 600 Ohms	on = 600 Ohms		off = Hi-Z	

Table 3. Settings for Analog Audio Channel 2

Data and GPIO Transport

This link includes three bi-directional asynchronous data channels that can transport signals up to 3 Mbps. These channels can be set with RS232 or RS422 levels by setting a switch, see table 1. In addition, there are four GPIO bidirectional channels and, a Tally with a front indicator. The General Purpose Input interface can be controlled with a short to ground (open collector), 3.3V, or 5V TTL levels. The General Purpose Output is an internal relay contact to ground that can safely switch up to 48V and up to 2A signal.

Gigabit Ethernet and Sync Option

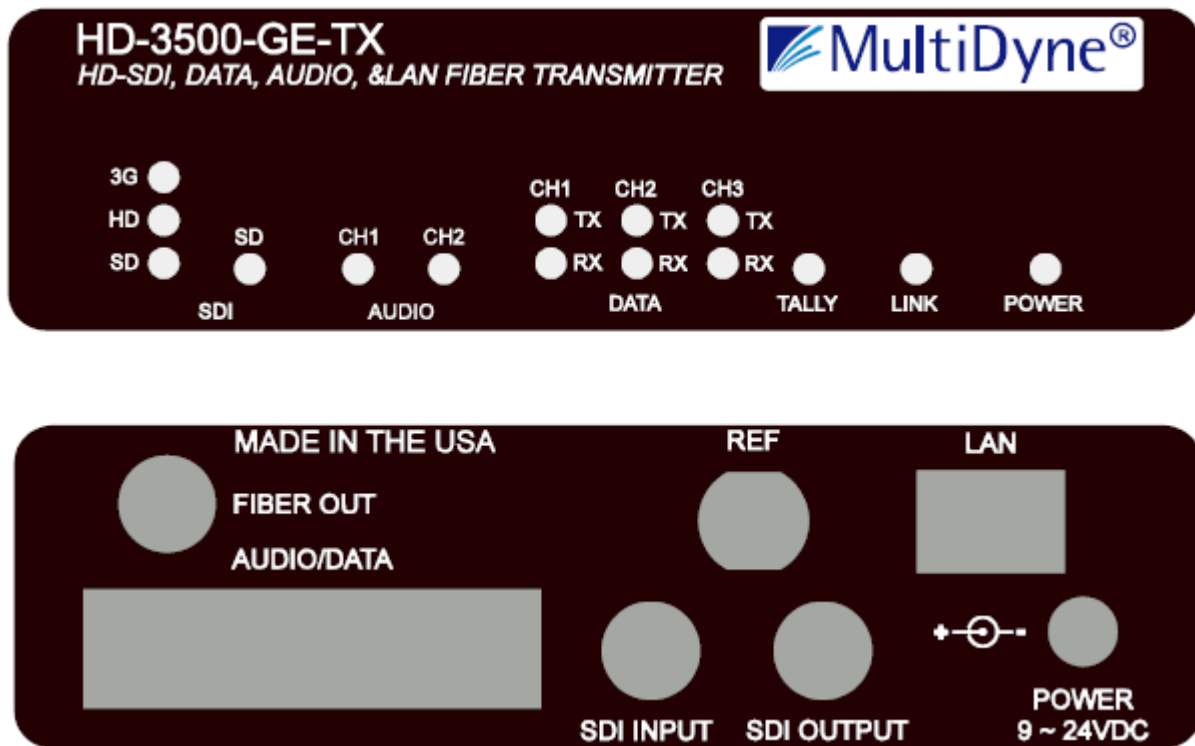

Figure 3. Front and Back of HD-3500-GE-TX

Reference Transport

The Gigabit Ethernet & Sync option, HD-3500-GE-TX, will output a reference genlock signal supplied by the HD-3500-GE-RX unit. Only the sync portion of the reference signal is transported across the fiber link, all video and color information is stripped from the signal. Supported formats include SD Black Burst (NTSC, PAL) and HD Tri-Level.

Ethernet Transport

The Gigabit Ethernet & Sync option, HD-3500-GE-TX, includes a copper to fiber Ethernet media converter. Data rates of 10/100/1000 Mbps are supported.

RECEIVER, HD-3500-FRX

The receiver module front and back is shown in figure 3. In the back and from left to right it includes: a DB44 connector for all audio and data IO, two SMPTE serial digital video 75 Ohm output BNC connectors for two reclocked SDI / HD-SDI outputs, a single fiber output ST or SC connector, and a DC Jack power connector. In the front of the module we see three SMPTE lock LEDs for 270 Mbps, 1.485 Gbps, or 2.970 Gbps rates; Fiber Signal Detector LED. Also included are 2 audio status LED that indicate channel 1 and 2 level and peak; 6 data activity LEDs to indicate TX and RX activity in the 3 data channels; a tally on indicator LED; a link status LED; and a power LED.

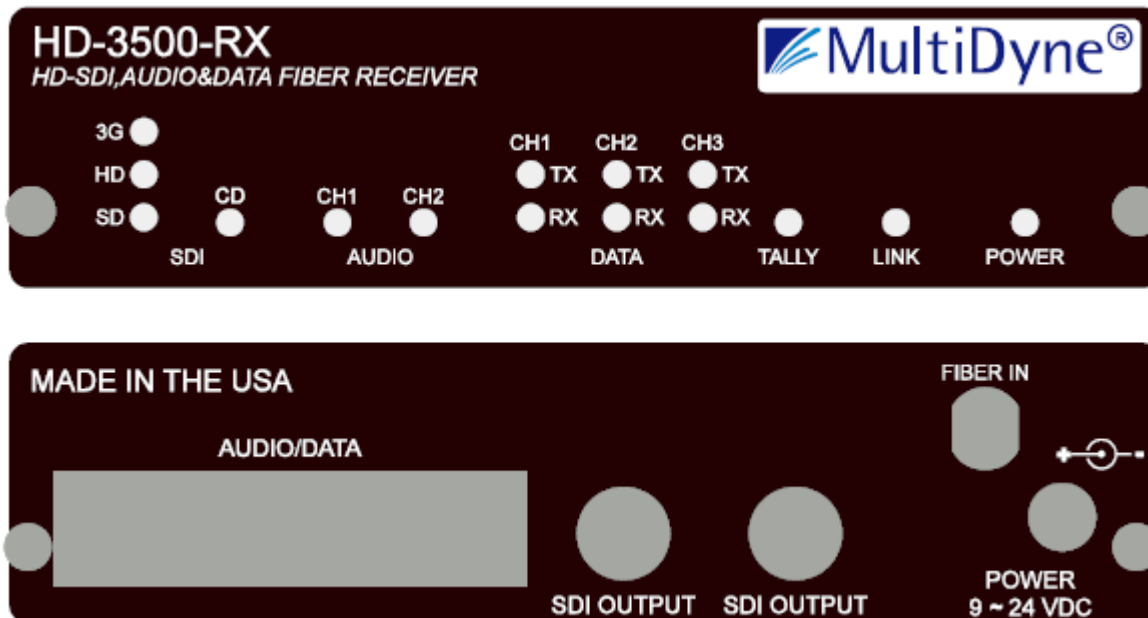

Figure 4. Front and Back of HD-3500-FRX

SMPTE transport

The HD-3500-RX receives the SMPTE video or other high-speed signals multiplexed along with audio and data from the fiber connector. These signals are optically de-multiplexed, and then sent to a reclocker to clean high frequency jitter created by return loss and fiber interfaces. The signals are then buffered and sent to the two 75-Ohm outputs with BNC connectors in the rear of the unit. Like in the TX side, the re-clocking capabilities work automatically when SMPTE rates are detected. The front rate LEDs indicate that a valid SMPTE video rate is locked by the re-clocker PLL. The Signal Detector (SD) LED indicates that a light signal has been applied to the optical interface and status. If the LED lights red, it means that the signal is heavily attenuated; typically less than -21dBm, there is nothing active connected on the fiber port, or the fiber is broken. A yellow light means the optical power is attenuated, typically less than -17dBm, but the link is still operative probably due to a long run of fiber or attenuation in the path.

Non-SMPTE transport via the SMPTE interface

This unit should work normally by default with SMPTE video signals at the rates indicated previously; however, other signals may need special settings. The reclocker will mute the output when noise or a not supported SMPTE rate is detected. This feature can be disabled when using other rates by setting SW4 on the PCB. Non-SMPTE standard signals should automatically put the reclocker in bypass mode; however, in some instances, if the signal has components close to the SMPTE frequencies, there may be glitches on the operation. To avoid this, there is another setting for SW4 to force the reclocker into bypass mode. See table 4 for SW4 settings.

Sw4 Position	ON Setting	Off Setting
1	Not Used	Not Used
2	Not Used	Not Used
3	Force reclocker bypass	Reclocker operates automatically with SMPTE rates
4	Disable SMPTE Auto-mute	SMPTE Auto-mute is on, use only with SMPTE

Table 4. SW4 Settings

Audio Transport

This link transports two balanced stereo pairs, or two AES channels of high quality audio. In the RX side, for each stereo pair, and whatever signal either analog or digital was selected at the TX side, is sent simultaneously to the analog and digital AES ports. This feature effectively can convert an analog signal in the TX side to digital in the RX side, or the reverse case. The AES channels can be set for 110 ohms balanced output mode or 75 Ohms singled ended output (see table 5). On the other hand, the analog stereo pairs can be set for different Full Scale (FS) levels using a dip switch (see table 6). The audio LEDs in the RX side indicate two possible statuses: green indicates analog level is present with a level from -8dBFS to -1dBFS, and red indicates clipping. Even if a tiny clip is detected, the red LED is held for a fraction of a second. In addition to these main audio channels, there is a bidirectional stereo channel for intercom applications. This channel has unbalanced inputs, and a maximum audio range of +4dBuFS.

Sw 2 Position	Function	Setting (Default values in Bold)	
1	AES 1 Output	on = 110 Ohms AES3 Bal. Input	Set off when position 2 = on
2	AES 1 Output	on = 75 Ohms AES3id Single Input	Set off when position 1 = on
3	AES 2 Output	on = 110 Ohms AES3 Bal. Input	Set off when position 4= on
4	AES 2 Output	on = 75 Ohms AES3id Single Input	Set off when position 3 = on

Table 5. Settings for AES Audio outputs

Sw 3 Position	Function	Setting (Default values in Bold)			
1-2	An. Audio 1 FS	on-on= 28dBu FS	on-off = 16dBu FS	off-on = 10dBu FS	off-off = 4dBu FS
3-4	An. Audio 2 FS	on-on= 28dBu FS	on-off = 16dBu FS	off-on = 10dBu FS	off-off = 4dBu FS

Table 6. Settings for Analog Audio Channel 2

Data and GPIO Transport

As introduced earlier, this link includes three bi-directional asynchronous data channels. These channels can be set with RS232 or RS422 levels by setting a switch, see table 7 for the selections in the RX side. These selections are independent from those in the TX side of the link allowing translation between RS-232 and RS-422 devices if needed. As in the TX side, we have the same four GPIO bidirectional channels and, a Tally with a front indicator in the RX side. Read the TX section of this manual for more information on GPIO.

Sw 1 Position	Function	Setting (Default values in Bold)	
1	Data 1 Type	on=RS232	off=RS422
2	Data 2 Type	on=RS232	off=RS422
3	Data 3 Type	on=RS232	off=RS422
4	TBD	-	-

Table 7. Settings for Data Types

Gigabit Ethernet and Sync Option

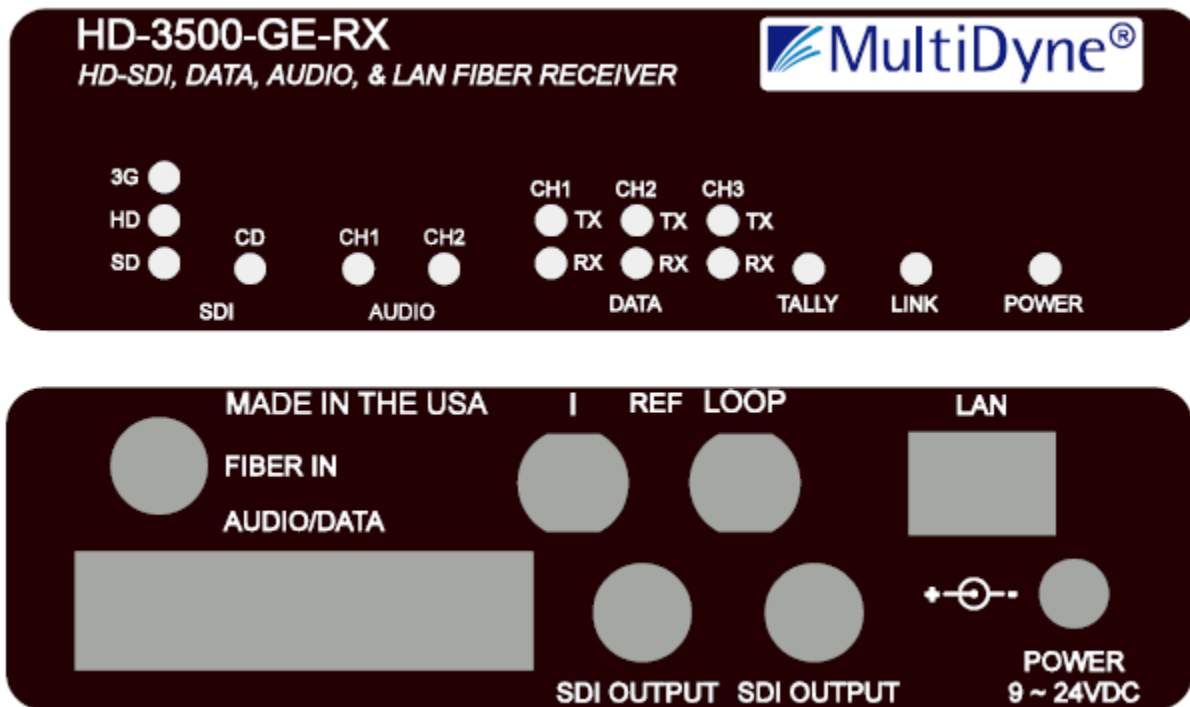

Figure 5. Front and Back of HD-3500-GE-RX

Reference Transport

The Gigabit Ethernet & Sync option, HD-3500-GE-RX, will send a reference genlock signal to the HD-3500-GE-TX unit. Two BNC's are provided, one for the input and the other as a loop-thru output. The reference signal must be terminated with a 75 ohm terminator, either on the loop output BNC or at the end of the loop if multiple units are being daisy chained together.

Only the sync portion of the reference signal is transported across the fiber link, all video and color information is stripped from the signal. Supported formats include SD Black Burst (NTSC, PAL) and HD Tri-Level.

Ethernet Transport

The Gigabit Ethernet & Sync option, HD-3500-GE-RX, includes a copper to fiber Ethernet media converter. Data rates of 10/100/1000 Mbps are supported.

POWER REQUIREMENTS

The HD-3500 Series operates from 110 or 220 VAC with the included wall-mount 12V power supply or other source in a range from 9 to 24 VDC and at least 25W of power. It uses a coaxial type connector (sleeve ground) on the rear panel labeled POWER. If desired, the units can be powered from a battery pack or automotive battery instead of the wall unit.

INSTALLATION

The installation and start up of the HD-3500 Series does not have special requirements. No special sequence must be followed to connect and start up the unit. RG59 or other 75 Ohms Coax cable must be used for the SDI inputs and outputs, and single mode fiber with the proper connectors must be used for the fiber link. Multimode fiber cannot be used reliably with the HD-3500. The HD-3500 Series come standard as stand-alone units. An optional rack-mounting kit is available to mount up to 3 units in a 1 Rack-unit or 1 ¾" by 19" rack space. The part number is -RMT.

APPENDIX A. Pin-Out specification

DB 44 Pin #	TX-3500-FTX			HD-3500-FRX		
	Dir	Name	Description	Dir	Name	Description
1	IN	A1L+	Analog Audio Ch1 Left In +	O	A1L+	Analog Audio Ch1 Left Out +
2	IN	A2L-	Analog Audio Ch2 Left In -	O	A2L-	Analog Audio Ch2 Left Out -
3	-	NC	Not Connected	-	NC	Not Connected
4	IN	ICL_IN	Intercom Left In	IN	ICL_IN	Intercom Left In
5	IN	GPI_4	General Purpose In 4	IN	GPI_4	General Purpose In 4
6	IN	DI_3-	Data In 3 - *	IN	DI_3-	Data In 3 - *
7	IN	AES1+	Digital Audio AES 1 +	O	AES1+	Digital Audio AES 1 +
8	IN	DI_3+	Data In 3 +	IN	DI_3+	Data In 3 +
9	O	ICL_OUT	Intercom Left Out	O	ICL_OUT	Intercom Left Out
10	O	ICR_OUT	Intercom Right Out	O	ICR_OUT	Intercom Right Out
11	O	GPO_1	General Purpose Out 1	O	GPO_1	General Purpose Out 1
12	-	NC	Not Connected	-	NC	Not Connected
13	O	DO_2-	Data Out 2 - *	O	DO_2-	Data Out 2 - *
14	IN	DI_2+	Data In 2 +	IN	DI_2+	Data In 2 +
15	IN	DI_1+	Data In 1 +	IN	DI_1+	Data In 1 +
16	IN	A1L-	Analog Audio Ch1 Left In -	O	A1L-	Analog Audio Ch1 Left Out -
17	IN	A1R+	Analog Audio Ch1 Right In +	O	A1R+	Analog Audio Ch1 Right Out +
18	IN	A2L+	Analog Audio Ch2 Left In +	O	A2L+	Analog Audio Ch2 Left Out +
19	-	NC	Not Connected	-	NC	Not Connected
20	IN	GPI_3	General Purpose In 3	IN	GPI_3	General Purpose In 3
21	IN	GPI_1	General Purpose In 1	IN	GPI_1	General Purpose In 1
22	IN	AES1-	Digital Audio AES 1 -	O	AES1-	Digital Audio AES 1 -
23	-	GND	Ground	-	GND	Ground
24	-	GND	Ground	-	GND	Ground
25	-	GND	Ground	-	GND	Ground
26	O	GPO_2	General Purpose Out 2	O	GPO_2	General Purpose Out 2
27	IN	TALLY_IN	Tally Input	IN	TALLY_IN	Tally Input
28	O	DO_2+	Data Out 2 +	O	DO_2+	Data Out 2 +
29	O	DO_1-	Data Out 1 - *	O	DO_1-	Data Out 1 - *
30	IN	DI_1-	Data In 1 - *	IN	DI_1-	Data In 1 - *
31	IN	A1R-	Analog Audio Ch1 Right In -	O	A1R-	Analog Audio Ch1 Right Out -
32	IN	A2R-	Analog Audio Ch2 Right In -	O	A2R-	Analog Audio Ch2 Right Out -
33	IN	A2R+	Analog Audio Ch2 Right In +	O	A2R+	Analog Audio Ch2 Right Out +
34	IN	ICR_IN	Intercom Right In	IN	ICR_IN	Intercom Right In
35	IN	GPI_2	General Purpose In 2	IN	GPI_2	General Purpose In 2
36	IN	AES2-	Digital Audio AES 2 -	O	AES2-	Digital Audio AES 2 -
37	IN	AES2+	Digital Audio AES 2 +	O	AES2+	Digital Audio AES 2 +
38	O	DO_3-	Data Out 3 - *	O	DO_3-	Data Out 3 - *
39	O	DO_3+	Data Out 3 +	O	DO_3+	Data Out 3+
40	O	GPO_4	General Purpose Out 4	O	GPO_4	General Purpose Out 4
41	O	GPO_3	General Purpose Out 3	O	GPO_3	General Purpose Out 3
42	O	TALLY_OUT	Tally Output	O	TALLY_OUT	Tally Output
43	O	DO_1+	Data Out 1 +	O	DO_1+	Data Out 1+
44	IN	DI_2-	Data In 2 - *	IN	DI_2-	Data In 2 - *

* Use always DO- / DI- (negative) for RS232 wiring

APPENDIX B. Block Diagrams

HD-3500 TX

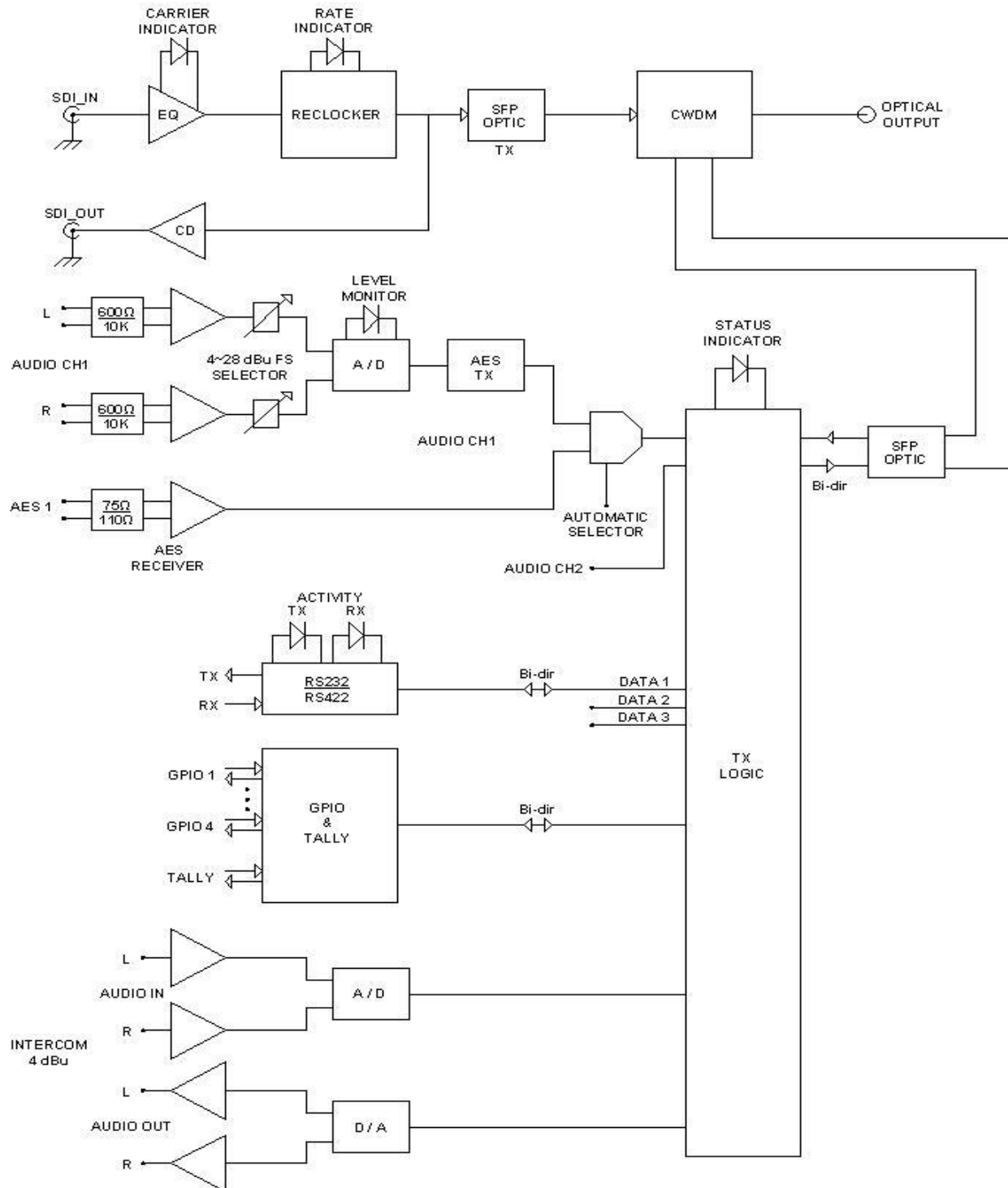

HD-3500 RX

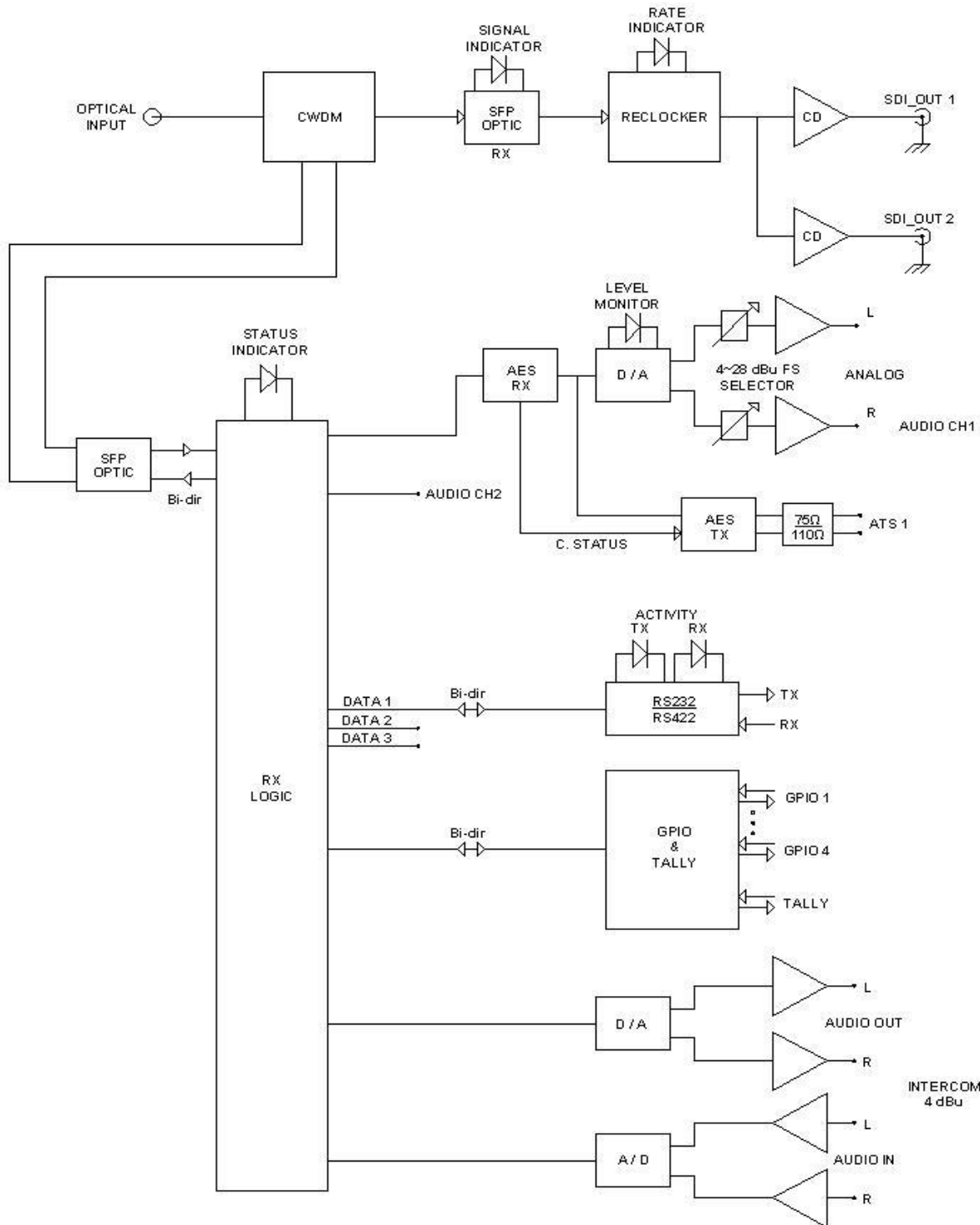

APPENDIX C. Technical Specifications

General

Power:	9-24V / 25W
Max Range with default Single Mode optics	up to 40Km
Fiber Connector Type	ST or SC
Standards Supported	SMPTE 259M-C SMPTE 292M SMPTE 425M SMPTE 297M DVB/ASI AES3 / AES3id RS232/RS422
Size, Standard Model	5.5"W x 6.5"D x 1.5"H
Size, -GE Option	5.75"W x 7.25"D x 1.7"H

Transmitter (-FTX)

SDI/HDSDI Transport:

Input Type	1 BNC
Input Impedance	75 Ohms
Loop Output Type.....	1 BNC
Loop Output Impedance	75 Ohms
Input and Loop Output Return Loss	>15dB up to 1.5GHz >10dB up to 3 GHz
Wavelength	1310nm Single mode
Optical Power	-2 dBm to 0 dBm
Laser Strength.....	Laser Class 1
Added Jitter:	<0.03UI under 1MHz

Audio:

Analog Input level selections	28/16/10/4 dBu FS
Bandwidth.....	+/- 0.5dB 20 to 20KHz
Analog Impedance input.....	20KOhm / 600Ohm
AES impedance input	75 / 110 Ohm
Intercom level	4 dBu FS
Intercom input impedance	10 KOhm
Intercom output impedance	< 50 Ohm

Data:

Data rates for	DC to 3Mbps
Input RS232 range	+/- 25V max, 2V min
Input RS422/485 range.....	-7V to 12V, 0.2V diff min
Out RS232 levels.....	+/- 5V
Out RS422/485 levels.....	0 / 2.3V
GPI off current (using open collector)	<1mA
GPI on voltage (using a voltage source)	2.5 to 5 V
GPO on switching current.....	2 A max
GPO on switching voltage	48V max

Reference Genlock Output (-GE option only):

Number of Outputs	1
Type	NTSC/PAL HD Tri-Level
Impedance.....	75 Ohms

Ethernet(-GE option only):

Number of Ports	1
Data Rate	10/100/1000 Base-T

Receiver (-FRX)

SDI/HDSDI Transport:

Wavelength	1100 to 1600nm
Optical Sensitivity	-20 dBm
Output Type	2 X BNC
Output Impedance	75 ohms
Output Return loss	>15 dB up to 1485MHz >10dB up to 3 GHz
Added Jitter:	<0.03UI under 1MHz

Audio:

Analog output level selections	28/16/10/4 dBu FS
Bandwidth.....	+/- 0.5dB 20 to 20KHz
THD.....	<0.01%
Analog Impedance output	< 10 ohm
AES impedance output	75 / 110 Ohm

Data:

Data rates for	DC to 3Mbps
Input RS232 range	+/- 25V max, 2V min
Input RS422/485 range.....	-7V to 12V, 0.2V diff min
Out RS232 levels.....	+/- 5V
Out RS422/485 levels.....	0 / 2.3V
GPI off current (using open collector)	<1mA
GPI on voltage (using a voltage source)	2.5 to 5 V
GPO on switching current.....	2 A max
GPO on switching voltage	48V max

Reference Genlock Input (-GE option only):

Number of Inputs	1
Number of Outputs	1 (looping input)
Type	NTSC/PAL HD Tri-Level
Impedance.....	75 Ohms

Ethernet(-GE option only):

Number of Ports	1
Data Rate	10/100/1000 Base-T

Specifications are subject to change without notice.

APPENDIX D. Optional Diving Board

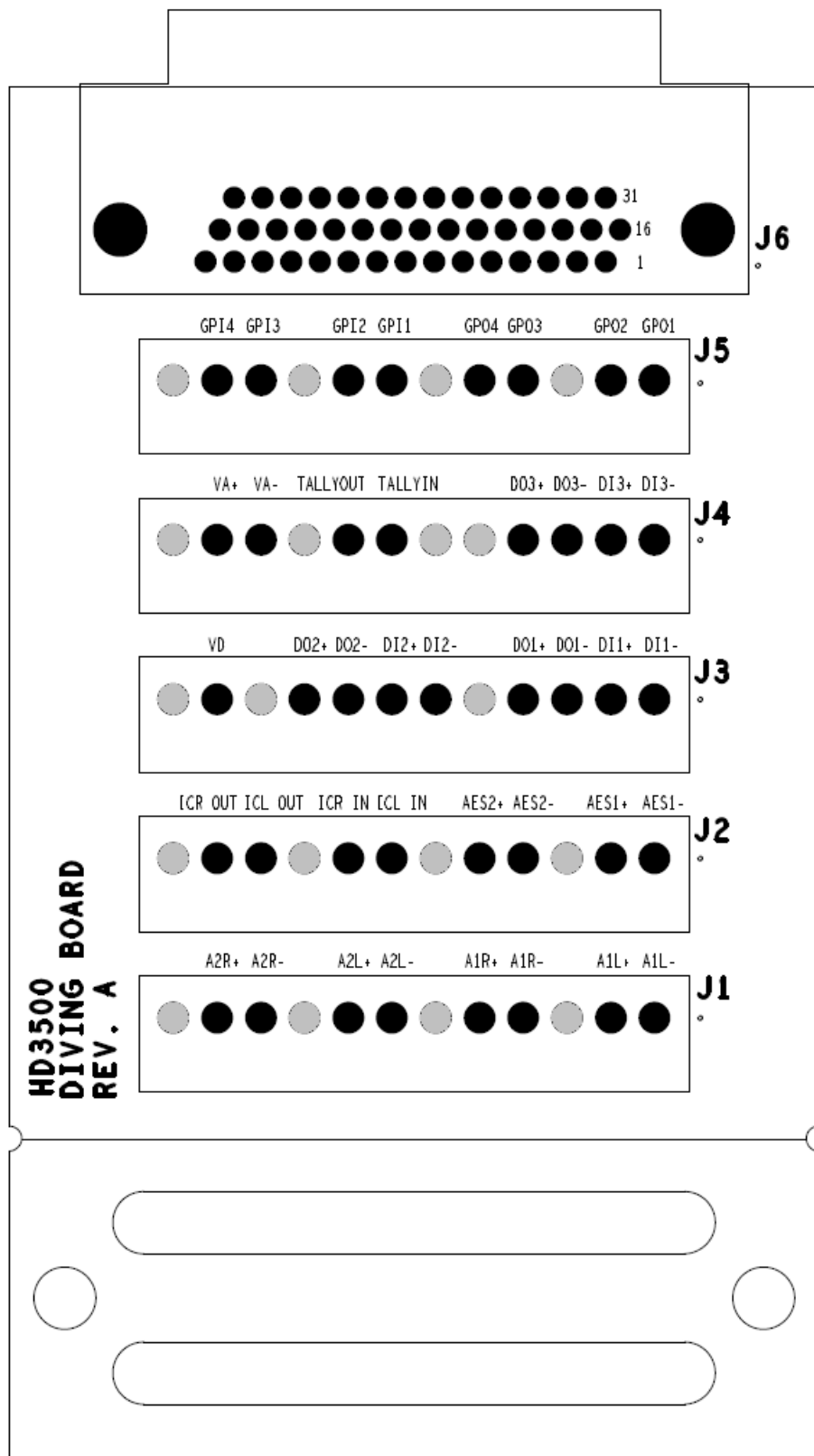

Terminal Block Pins

Non-labeled gray pins are ground

GPI: General Purpose Input
GPO: General Purpose Output

Vn+/- : Test Voltage (Not Connect)
TALLY OUT/IN
DI n+/- : RS232/RS422 Input
DO n+/- : RS232/RS422 Output

Use always DO- / DI- (negative) for RS232 wiring

ICR/L OUT: Intercom Right/Left Outputs
ICR/L IN: Intercom Right/Left Inputs
AESn+/-: AES Inputs in TX, Outs in RX

AnR/L +/-: Analog Audio Inputs in TX
Analog Audio Outputs in RX

*For RS485 applications connect together DO and DI with a small 680 Ohm resistor as shown below.

