



INSTRUCTION MANUAL
DVM-2500/DAM-2500

**12 bit, BI-DIRECTIONAL, ANALOG VIDEO,
AUDIO & DATA FIBER OPTIC
TRANSPORT SYSTEM**

10 Newton Place
Hauppauge, NY 11788 USA
(800)-488-8378 / (516)-671-7278 FAX (516)-671-3362
sales@multidyne.com
www.multidyne.com

MULTIDYNE and DVM-2500 are registered trademarks of MULTIDYNE Electronics, Inc.

Copyright 2015 MULTIDYNE Electronics, Inc., Hauppauge, New York. All Rights Reserved.
Contents of this publication may not be reproduced in any form without the written permission
of MULTIDYNE Electronics, Inc.

This product was designed and manufactured in the
UNITED STATES of AMERICA

TABLE OF CONTENTS

INTRODUCTION.....	1
FEATURES AND OPERATION.....	1
VIDEO CHANNEL.....	1
FRONT PANEL, DVM-2500-TRX.....	1
REAR PANEL, DVM-2500-TRX	2
AUDIO CHANNELS	3
DATA CHANNELS, TALLY AND ALARM	3
OPTICAL OPTIONS.....	5
INSTALLATION	5
CIRCUIT DESCRIPTION	5
APPENDIX A: SPECIFICATIONS	6
APPENDIX B: DRAWINGS	7
DVM-2500-TRX SCREW TERMINAL ADAPTER, DVMAUDIO25	7
APPENDIX C: BLOCK DIAGRAM	8

INTRODUCTION

The DVM-2500 Bi-directional, 12 Bit Video and 24 Bit Audio Fiber Optic Transport offers state-of-the-art performance exceeding RS250C Short-haul and Broadcast Specifications with a Signal to Noise ratio exceeding 75 dB. The system will support 1 video, 8 audio, 2 data and 1 tally channel bi-directionally over one fiber. The system includes an optical module with an integrated wave-division multiplexer, laser transmitter and pin receiver. The digital information is transported through the fiber at the 1310nm wavelength in one direction and at the 1550nm wavelength in the other direction. Applications include links from studio to transmitter, studio to studio, studio to CATV head-end, distance learning and backhaul feeds from special events. The transmit and receive units are available in portable and rack-mount packages making the system ideal for both field and studio applications.

FEATURES and OPERATION

VIDEO CHANNEL

The video performance of the fiber optic system exceeds RS-250C Short-haul specifications. The system uses state-of-the-art technology to offer a true 12 bit Video Analog to digital conversion and a 24 bit Audio A to D conversion. By using 12 bits we are able to achieve a Signal to Noise ratio of over 75 dB. The system is ultra linear and distortion free giving differential gain and phase of less than 0.2 % and 0.2 degrees, respectively. The video input and output signals are back-porch clamped. The system has a video bandwidth of 6.5 MHz. The transmission of NTSC, PAL, SECAM and video with diplexed audio carriers at 4.5 MHz, 5.8 MHz and 6.4 MHz are fully compatible with the fiber optic system.

FRONT PANEL, DVM-2500-TRX

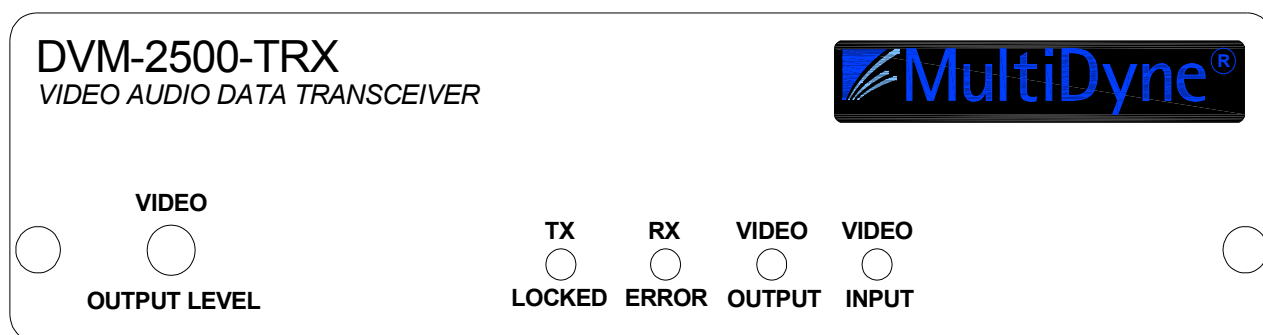

Fig. 1 Front Panel

The unit front panel, shown in Fig. 1, has a **VIDEO OUTPUT LEVEL** control for adjusting the received video level. It also includes **VIDEO INPUT** and **VIDEO OUTPUT** LEDs to indicate presence of input and output video signals, respectively. The **TX LOCKED** LED indicates that the transmitter multiplexer is locked and sending data. The **RX ERROR** LED indicates that the receiver multiplexer is failing to lock. This can also indicate an optical failure.

REAR PANEL, DVM-2500-TRX

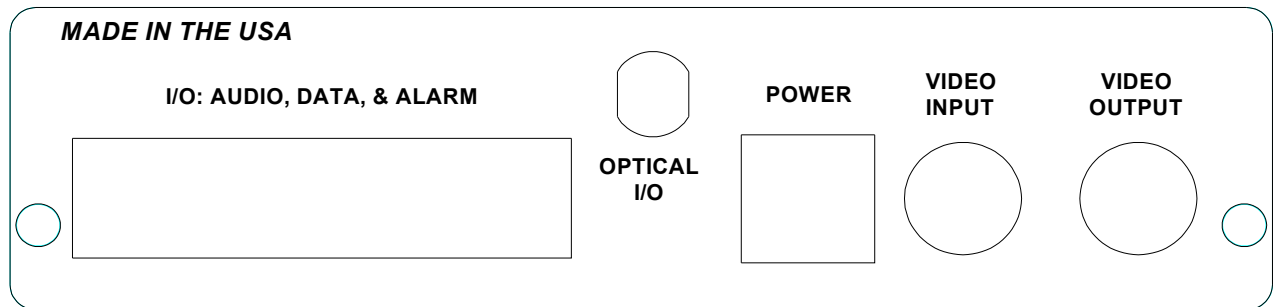

Fig. 2 Rear Panel

The DVM-2500 rear panel, shown in Fig.2, has a 44-pin D-type connector labeled **AUDIO & DATA I/O & ALARM**. All the audio, data, tally and alarm I/O's are made through this connector. The pinning of this connector is given in table 1 below. See the AUDIO CHANNELS and DATA CHANNELS sections below for a description of the signals. The unit comes standard with a male 44-pin D-type connector with solder cups for hand wiring of the interconnections. See APPENDIX B: DRAWINGS, Wiring Diagram for 44 Pin Connector for details. An optional DVMAUDIO25 Screw Terminal Audio Adapter and DVMXLR25 XLR Audio Adapter is available. See APPENDIX B: DRAWINGS, Screw Terminal Adapter. The **POWER** connector is for the included 110 or 220 VAC wall-mount power supply. The **OPTICAL I/O** default connector is of type ST unless otherwise specified. The **VIDEO INPUT** and **VIDEO OUTPUT** BNC connectors are on the rear panel as well.

Pin	Type	Signal	Pin	Type	Signal	Pin	Type	Signal
1	IN	A1T+	16	IN	A1T-	31	IN	A2T-
2	IN	A3T-	17	IN	A2T+	32	IN	A4T-
3	IN	A5T-	18	IN	A3T+	33	IN	A4T+
4	IN	A5T+	19	IN	A6T-	34	IN	A6T+
5	IN	A8T+	20	IN	A8T-	35	IN	A7T+
6	OUT	A3R-	21	IN	A7T-	36	OUT	A2R-
7	OUT	A1R+	22	OUT	A1R-	37	OUT	A2R+
8	OUT	A3R+	23		GND	38	OUT	A4R-
9	OUT	A5R+	24	OUT	A5R-	39	OUT	A4R+
10	OUT	A6R+	25	OUT	A6R-	40	OUT	A8R+
11	OUT	A7R-	26	OUT	A7R+	41	OUT	A8R-
12	OC	ALARM	27	IN	TALLY IN	42	OUT	TALLY OUT
13	OUT	~DO2	28	OUT	DO2	43	OUT	DO1
14	IN	DI2	29	OUT	~DO1	44	IN	~DI2
15	IN	DI1	30	IN	~DI1			

Table 1 Audio, Data and Alarm Connector Signals

AUDIO CHANNELS

The fiber optic system includes 8 channels (4 stereo pairs) of high quality CD grade audio encoded in 24 bits in each direction. The balanced audio inputs are configured as High impedance by default. A 600 Ohm termination can be found on the optional –DVMAUDIO screw terminal audio adapter board. The 600 Ohm termination may be removed for high impedance operation. The balanced audio outputs have a source termination of 50 Ohms. The system is able to accommodate a maximum input and output level of +18 dBu. The input level to the transmitter should not exceed +18 dBu. The 8 audio inputs for the “T” for transmitter side are labeled **A1T+**, **A1T-** through **A8T+**, **A8T-** respectively. See Table 1 above. The 8 audio outputs for the “R” for receiver side are labeled **A1R+**, **A1R-** through **A8R+**, **A8R-** respectively. The terminal(s) labeled **G** or **GND** are the audio ground connections.

DATA CHANNELS, TALLY and ALARM

The fiber optic system can accommodate 2 simplex data channels in each direction (2 full duplex in total). Only point to point and “4 wire” operation is supported. Multipoint or “2 wire” RS485 is not supported.

Internal jumpers on the PCB are used to set the data ports to the RS232 or RS422 protocol. Default settings are RS232. To open the unit and set the jumpers to RS422, remove the 2 front panel screws, front panel, and bezel, and slide the top cover off. The jumpers are a 2x6 header that is located at the extreme upper right (right rear) corner of the PCB next to the 44-pin I/O connector. The top row of jumpers selects whether or not internal 100 ohm terminations are present. The bottom row selects the protocol. The default settings for RS232 are shown in Fig. 3 below. Terminations are never used for RS232. In RS422, the terminations are normally used if there are no other terminations present anywhere in the link other than the internal ones selected on the PCB. See Fig. 4 below. If, however, external terminations are present, then the top row of jumpers should remain in the RS232 position. See Figure 5 below.

The 2 differential data channel input connections are labeled as **DI1**, **~DI1**, **DI2**, and **~DI2** where “~” indicates NOT or INVERTED. The 2 differential data channel output connections are labeled as **DO1**, **~DO1**, **DO2**, and **~DO2**. The terminal(s) labeled **G** or **GND** are the data ground connections. When using RS232, connect the single-ended signal between the “~” terminals and **GND**. Leave the other polarity floating. When using RS422, connect the differential signal between both polarities. The **TALLYIN** and **TALLYOUT** (**TAIN** and **TAOUT** on the adapter board) are the respective input and output connections for the tally signal. A logic high on **TALLYIN** causes a dry contact closure to ground on **TALLYOUT**. The wet **ALARM** terminal is an open collector output that conducts on a loss of data or error on the receive side.

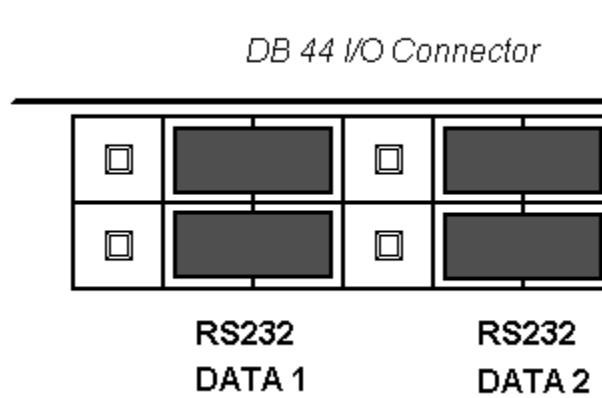

Fig. 3: Jumper Settings for RS 232 (Default)

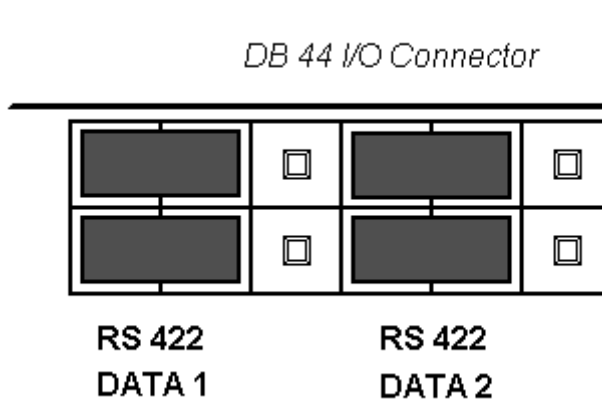

Fig. 4: Jumper Settings for RS 422 with internal termination

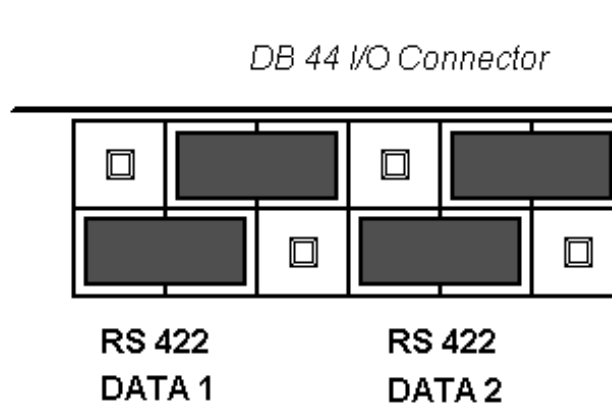

Fig. 5: Jumper Settings for RS422 without internal terminations

OPTICAL OPTIONS

The DVM-2500 in the standard configuration uses a 1310 or 1550nm Single mode laser with a 0 dBm output power. The launched optical power can vary from -8 dBm to +3 dBm depending on the model purchased. The 1310 or 1550nm pin receivers typically have a sensitivity of -24dBm. All of the lasers offered are Class 1 compliant.

INSTALLATION

Extreme caution should be used when handling Laser equipment. Direct exposure to the eyes can be harmful. The video, audio, data and optical connections can be found in the sections above. There are no user serviceable parts or adjustments inside the system. Except for the data protocol settings, the only user controls and interfaces are present on the front and rear panels. If service or calibration adjustments are necessary please return the system to the factory. Complementary units can ONLY be used during installation. A DVM2500-TRX-5/3 1550nm Transmitter and 1310nm Receive unit should always be matched with a DVM2500-TRX-3/5 1310nm Transmitter and 1550nm Receive unit. The receiver will compensate for variations in optical attenuation, and will operate with optical signals from -24 to +3 dBm without overload.

CIRCUIT DESCRIPTION

The Multidyne DVM2500 is a highly linear low noise, low distortion fiber optic link. The circuitry in the transmitter processes and digitizes the analogue video and audio signals and, through high speed time division multiplexing, performs a parallel to serial conversion that combines them with the data and tally signals into a single, self clocking bit stream that modulates a LED or a laser. At the receiving end a PIN diode converts the optical signal back to a serial data stream, and a high speed de-multiplexer performs a serial to parallel conversion that extracts the imbedded clock, data and tally signals, along with the digital audio and video in a parallel format which is presented to digital to analogue converters that reconstruct the analogue signals. The units include an integrated wave-division multiplexer that directs the correct wavelengths of light to and from PIN and laser, enabling use of a single fiber. See APPENDIX C for a block diagram of one unit. Two units are required for a link.

APPENDIX A: SPECIFICATIONS

Video Performance:

Signal to noise	> 75 dB
Differential gain.....	< +/- 0.2 %
Differential phase.....	< +/- 0.2°
Chrominance to luminance gain	< +/- 0.5 %
Chrominance to luminance delay.....	< +/- 5 ns
Frequency response to 6.0 MHz.....	< +/- 0.05 dB
Video Bandwidth.....	6.5 MHz
Luminance non-linearity.....	< 0.2 %
Ringing	< +/- 0.5 %
Tilt	< +/- 0.2 %
Video output & input impedance	75 Ohms

Audio Performance:

Audio Channels	4 stereo or 8 mono
Signal to noise	> 90 dB
Frequency response to 20 Hz to 20 KHz	< +/- 0.1 dB
Distortion	< 0.05 %
Audio output level, adjustable	Unity, +/- 6 dBu
Maximum input & output level.....	+18 dBu
Audio output impedance, balanced.....	50 Ohms
Audio input impedance, balanced.....	600 Ohms or High

General:

Data Channels.....	2, RS232 or RS422
Max Recommended Data Rate.....	9600 baud
Laser Power	-8 ~ +3 dBm, Class 1
Power Requirement.....	110 or 220VAC <15W
Operating temperature.....	0 to +50 °C
Portable and Wall-mount:	7" L x 5 3/4" W x 1 3/4" H
Triple Rack-mount Kit for 3 modules (Part number -RMT):	7" L x 19" W x 1 3/4" H

Specifications subject to change without notice.

APPENDIX B: DRAWINGS

DVM-2500-TRX Screw Terminal Adapter, DVMAUDIO25

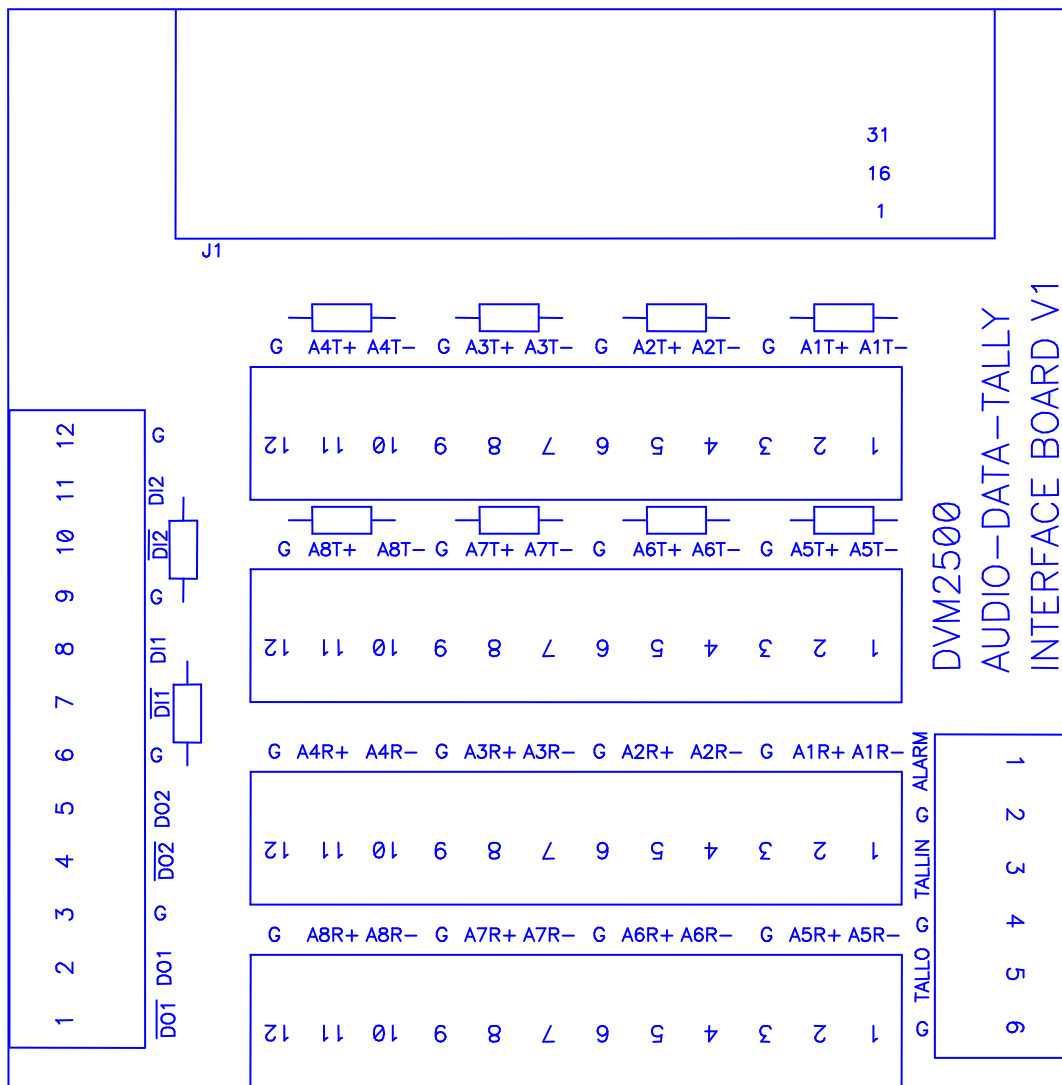

APPENDIX C: BLOCK DIAGRAM

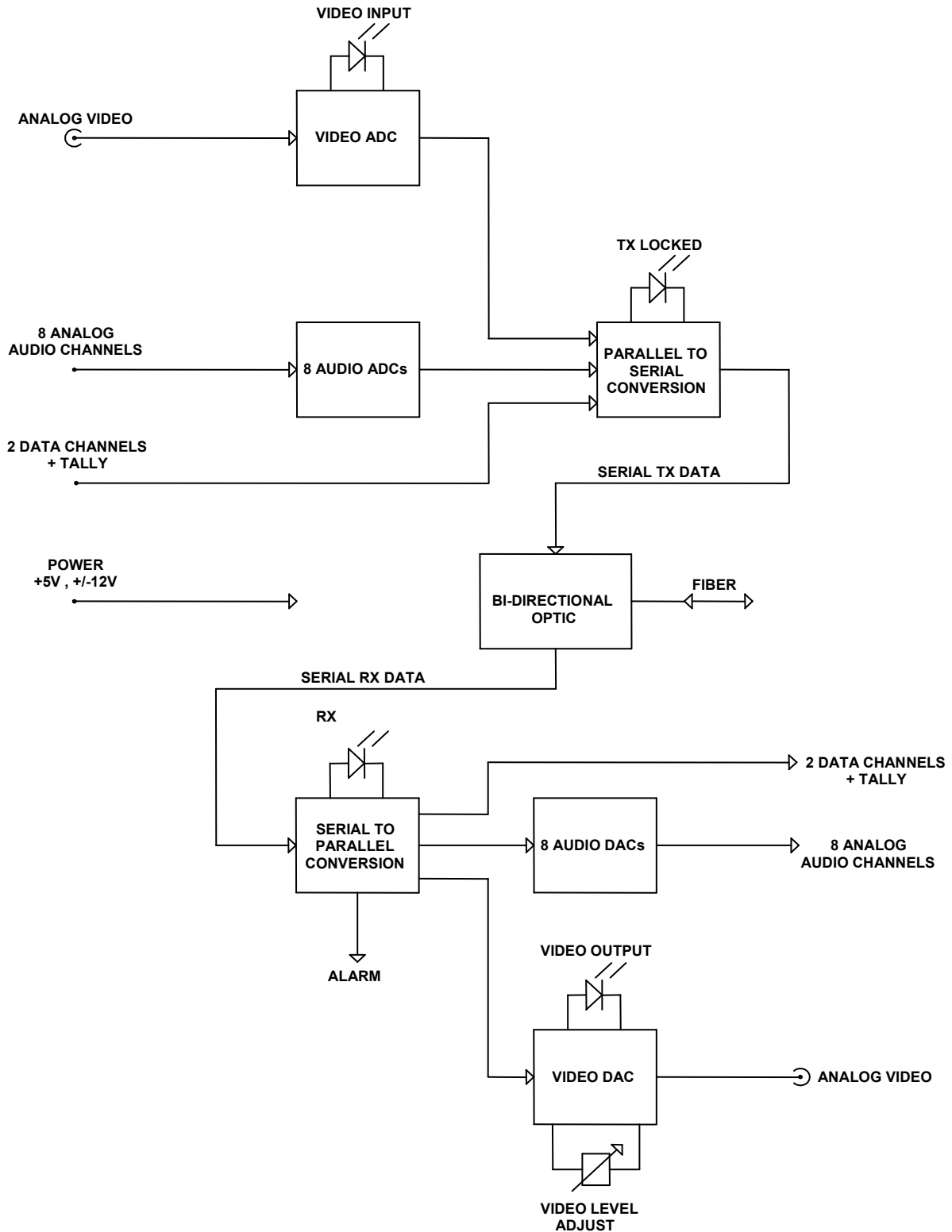

APPENDIX D: AUDIO PIN OUT DIAGRAM

DVM-2500

44 Pin Audio, Data, Tally and Alarm I/O's, Figure 1

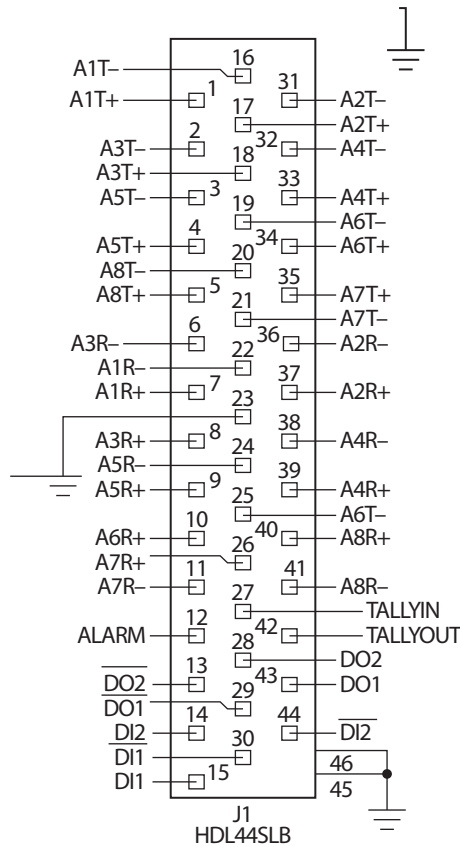

For RS485 applications: Connect together with a 680 Ohm resistor DI+ and DO+, DI- and DO- (on both sides), then connect RS485 + wire to DI+, and RS485- to DI-. Select RS422 data (inside DVM-2500, back right corner of PCB).