

INSTRUCTION MANUAL

DTV-4000

**4 Ch. SDI & 16 Ch. AUDIO
FIBER OPTIC MULTIPLEXER
TRANSPORT SYSTEM AND
FRAME SYNCHRONIZER**

MULTIDYNE Electronics, Inc.

Innovations in Television Testing & distribution

1-(800)-4TV-TEST, 1-(800)-488-8378

191 FOREST AVENUE
LOCUST VALLEY, NY 11560-2132 USA
(516)-671-7278 FAX (516)-671-3362

MULTIDYNE and DVT-40 oh 00 are registered trademarks of MULTIDYNE Electronics, Inc.

Copyright 2001 MULTIDYNE Electronics, Inc., Locust Valley, New York. Printed in the United States of America. All Rights Reserved. Contents of this publication may not be reproduced in any form without the written permission of MULTIDYNE Electronics, Inc.

This product was designed and manufactured in the
UNITED STATES of AMERICA

TABLE OF CONTENTS

INTRODUCTION	4
<hr/>	
FEATURES AND OPERATION	4
<hr/>	
SDI CHANNELS	4
TRANSMITTER, DTV-4000-FTX	4
RECEIVER, DTV-4000-FRX	5
AUDIO CHANNELS	5
OPTICAL OPTIONS	5
INSTALLATION AND SETUP	5
POWER REQUIREMENTS	6
SPECIFICATIONS	6
<hr/>	
DRAWINGS	7
<hr/>	
DTV-4000-FTX TRANSMITTER D-TYPE CONNECTOR WIRING DIAGRAM	7
DTV-4000-FRX RECEIVER D-TYPE CONNECTOR WIRING DIAGRAM	7

INTRODUCTION

The DTV-4000, transporting 4 channels of 10 Bit 270MSPS SMPTE-259M SDI and 16 channels of 24 Bit Audio, offers state-of-the-art Fiber Optic transport performance. The system will support 4 SDI and up to 16 audio per optical wavelength. The 4 SDI sources need not be synchronous to each other or to an external reference. In addition, the DTM4000-FRX offers the option of frame-synchronizing the 4 SDI outputs to a local reference sync, which can be composite sync or black burst. The user can advance or delay the SDI outputs with respect to the reference sync.

The user can (WDM) Wave Division Multiplex, permitting multiple optical sources to share a single fiber, multiplying the capacity of fiber optic cables by a factor of eight. Applications include links from studio to transmitter, studio to studio, studio to CATV head-end, distance learning and backhaul feeds from special events.

FEATURES and OPERATION

!!!!!! DANGER !!!!!

INVISIBLE LASER RADIATION

AVOID DIRECT EXPOSURE TO BEAM

OUTPUT POWER MAX: 2 mW. WAVELENGTH: 1300/1550 NM. CLASS III b LASER

The optical laser transmitter may harm the human eye. Proper eye protection should be used at all times when working with laser. Please read the entire manual before operating the Fiber Optic devices.

WARNING

**The unit should be only serviced or opened by qualified personnel.
There are no user serviceable parts or adjustments inside.**

SDI CHANNELS

The system can support 270MSPS SMPTE 259M digital video. Both 525 and 625 line formats are supported. At this time, 143, 177, 360 or 540 MBPS formats cannot be supported.

TRANSMITTER, DTV-4000-FTX

The transmitter unit, designated by model number DTV-4000-FTX, includes (4) **SDI INPUT** BNC connectors on the rear of the unit. The transmitter front panel includes (4) **SDI PRESENT** LED's to indicate the delivery of valid 270MSPS SDI signals when illuminated green. The **LOCK** LED indicates that the multiplexer is locked and operational when green. The **POWER** LED indicates that power is ON.

RECEIVER, DTV-4000-FRX

The receiver unit, designated by model number DVM-4200-FRX, includes (4) **SDI OUT** BNC connectors on the rear panel, and, if the Frame Sync option is installed, a **GENLOCK** input BNC connector. The receiver front panel includes (4) **SDI PRESENT** LEDs indicating the presence of valid SDI when green. The **LOCK** LED indicates that the decoder multiplexer is locked when green. The (3) **PHASING** controls are for adjusting output timing, if the frame sync option has been installed. There is also a **GENLOCK PRESENT** LED, which, if the Frame Sync option is installed, will glow when a **GENLOCK** signal is present. The **POWER** LED indicates that power is ON.

AUDIO CHANNELS

The fiber optic system includes 16 channels of high quality CD grade audio encoded in 24 bits. The balanced audio inputs are High impedance by default. When the optional – DVMAUDIO4000 Screw Terminal Adapters are used, the input impedance is 600 Ohms by default. The 600-Ohm termination may be removed for high impedance operation. The balanced audio outputs have a source termination of 50 Ohms. The system is able to accommodate a maximum input and output level of +18 dBm with a 600-Ohm termination. The input level to the transmitter should not exceed +18 dBm. The audio I/Os are brought to a DB-44 type connector on the rear panel. When using the optional –DVMAUDIO4000 adapter board, the audio I/O's are labeled **A1+**, **A1-** through **A16+**, **A16-** respectively. The terminal labeled **GND** is the audio ground connection.

OPTICAL OPTIONS

The DTV-4000 Fiber Optic system is available in several different optical configurations. There are multi-mode systems available with 1310 nm wavelengths. The multi-mode systems are available with ST connectors. The Singlemode laser systems are available in 1310 nm and 1550 nm wavelengths with ST, SC or FC connectors. The 1310 nm single-mode laser system is available with -8 dBm, -3 dBm, 0 dBm and +3 dBm optical powers. The 1550 nm single-mode laser system is available in an optical power of +3 dBm. Please read the section **INSTALLATION and SETUP** for further information.

INSTALLATION AND SETUP

Extreme caution should be used when handling Laser equipment. Appropriate eye protection should be worn at all times. Direct exposure to the eyes and skin can be harmful. The video, audio, data and optical connections can be found in the sections above. There are no user serviceable parts or adjustments inside the system. The only user controls and interfaces are present on the front and rear panels. If service or calibration adjustments are necessary please return the system to the factory.

When installing a 1310 or 1550 nm Singlemode Laser system the launched optical power can vary from -8 dBm to +3 dBm depending on the model purchased. The receiver will compensate for variations in optical attenuation. The receiver unit will operate with an optical signal from –30 to +2 dBm without over-load.

The DTV-4000-FRX Fiber Optic Receiver for Singlemode applications all has an optical window from the wavelength of 1100 to 1600 nm. If a Singlemode system is to be WDM, wave division multiplexed or CWDM, coarse wave division multiplexing with other optical wavelengths in the 1100 to 1600 nm range, the appropriate optical filters and wave division multiplexers should be used. The user may contact MULTIDYNE to purchase such devices.

If the Frame Sync option is installed, the user has the ability to adjust the timing of the 4 output SDI signals with respect to the **GENLOCK** signal. The **GENLOCK** signal can be any RS-170 type NTSC or PAL composite video or black burst signal. There are 3 **PHASING** controls, a fine, medium, and coarse adjustment going from left to right. Each control has 16 steps except for the coarse control, which has 8. The fine control has a resolution of 37ns per step; the medium control, 592ns; and the coarse control, 9.48us. Using the 3 controls thus gives a total of 16x16x8 or 2048 steps of 37ns, for a total range of 75.8us of adjustment. When the controls are set to the centers of their range, which is 7, 7, and 3, for fine, medium, and coarse, respectively, the timing is such that the horizontal EAV in the SDI outputs as they emerge from the DTV4000-FRX should be approximately aligned with the leading edge of the **GENLOCK** h-sync. If the Frame sync option is not installed, or the **GENLOCK** signal is not present, the SDI outputs will be delayed by approximately 1 video frame from the inputs at the FTX, plus the system latency, which includes that of the optical path, which cannot be predicted.

POWER REQUIREMENTS

The units operate from universal AC input desktop supplies. Power requirement is approximately 100 – 250VAC @ 800ma max.

SPECIFICATIONS

SDI:

Input/output impedances.....	75 ohms
Sample Rate:.....	270 MBPS
Format:.....	SMPTE-259M

Audio Performance:

Signal to noise	> 90 dB
Frequency response to 20 Hz to 20 KHz	< +/- 0.1 dB
Distortion	< 0.05 %
Audio output level	Unity
Maximum input & output level, 600-Ohm termination	+18 dBm
Audio output impedance, balanced	50 Ohms
Audio input impedance, balanced (selectable) ..	600 Ohms or High

Power:

Power dissipation	< 30 Watts, per unit
AC/DC operation	85 - 265 VAC
Operating temperature	0 to +50 °C

Specifications subject to change without notice.

DRAWINGS

DTV-4000-FTX Transmitter D-type Connector Wiring Diagram

DTV-4000-FRX Receiver D-type Connector Wiring Diagram

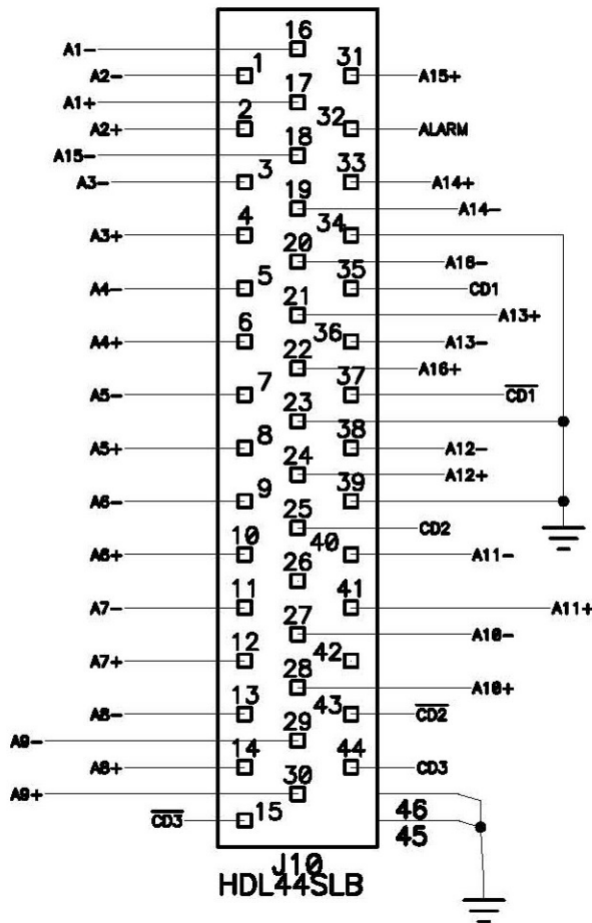

The 44-pin audio and data connector is the same for RX and TX. On the TX the pins are inputs. On the RX they are outputs. Balanced audio pairs are designated A1+/A1- thru A16+/A16-. Differential data connections are designated by CD1/CD1not thru CD3/CD3not. For single-ended protocols such as RS232 data, connect to the not pin and gnd. The alarm is open collector.